



(19) **United States**
(12) **Patent Application Publication**
NIELSEN et al.

(10) **Pub. No.: US 2010/0188088 A1**
(43) **Pub. Date: Jul. 29, 2010**

(54) **METHODS AND APPARATUS FOR DISPLAYING AND PROCESSING FACILITIES MAP INFORMATION AND/OR OTHER IMAGE INFORMATION ON A LOCATE DEVICE**

filed on Feb. 11, 2009, provisional application No. 61/102,169, filed on Oct. 2, 2008, provisional application No. 61/102,122, filed on Oct. 2, 2008.

Publication Classification

(75) Inventors: **STEVEN NIELSEN**, NORTH PALM BEACH, FL (US); **CURTIS CHAMBERS**, PALM BEACH GARDENS, FL (US); **JEFFREY FARR**, JUPITER, FL (US)

(51) **Int. Cl.**
G01V 3/10 (2006.01)
G01C 21/00 (2006.01)
G09G 5/00 (2006.01)
(52) **U.S. Cl.** **324/329; 701/213; 345/649**

Correspondence Address:
WOLF GREENFIELD & SACKS, P.C.
600 ATLANTIC AVENUE
BOSTON, MA 02210-2206 (US)

(73) Assignee: **CERTUSVIEW TECHNOLOGIES, LLC**, PALM BEACH GARDENS, FL (US)

(57) **ABSTRACT**

A locate device for a locate operation to detect a presence or an absence of one or more underground facilities is configured to access and display facilities map information, and/or other image information, as a visual aid to facilitate the locate operation. In various aspects, methods and apparatus relate to: selection of an appropriate "base" facilities map, or information from a database of facilities map data, relating to a given work site/dig area; selection of an appropriate pan and/or zoom (resolution) for displaying facilities map information; appropriately updating displayed facilities map information while a locate device is used during a locate operation (e.g. changing pan, zoom and/or orientation); overlaying on the displayed facilities map information locate information and/or landmark information relating to the locate operation; and storing locally on the locate device, and/or transmitting from the locate device, facilities map information and/or overlaid locate/landmark information (e.g., for further processing, analysis and/or subsequent display).

(21) Appl. No.: **12/701,500**
(22) Filed: **Feb. 5, 2010**

Related U.S. Application Data

(63) Continuation-in-part of application No. 12/571,356, filed on Sep. 30, 2009, Continuation-in-part of application No. 12/649,535, filed on Dec. 30, 2009, Continuation-in-part of application No. 12/571,329, filed on Sep. 30, 2009.
(60) Provisional application No. 61/151,568, filed on Feb. 11, 2009, provisional application No. 61/151,778,

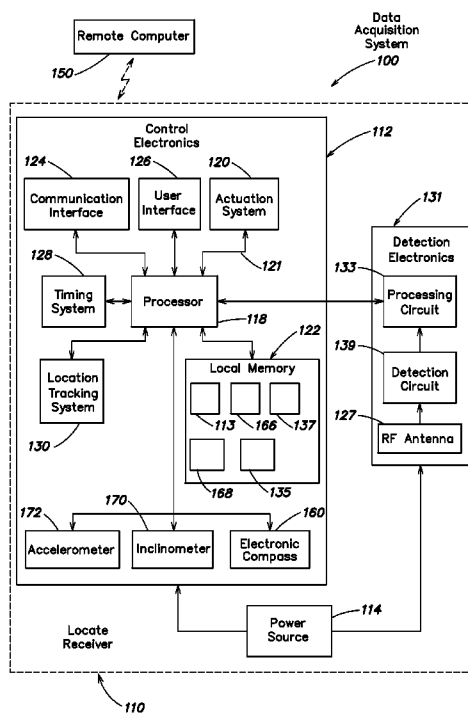

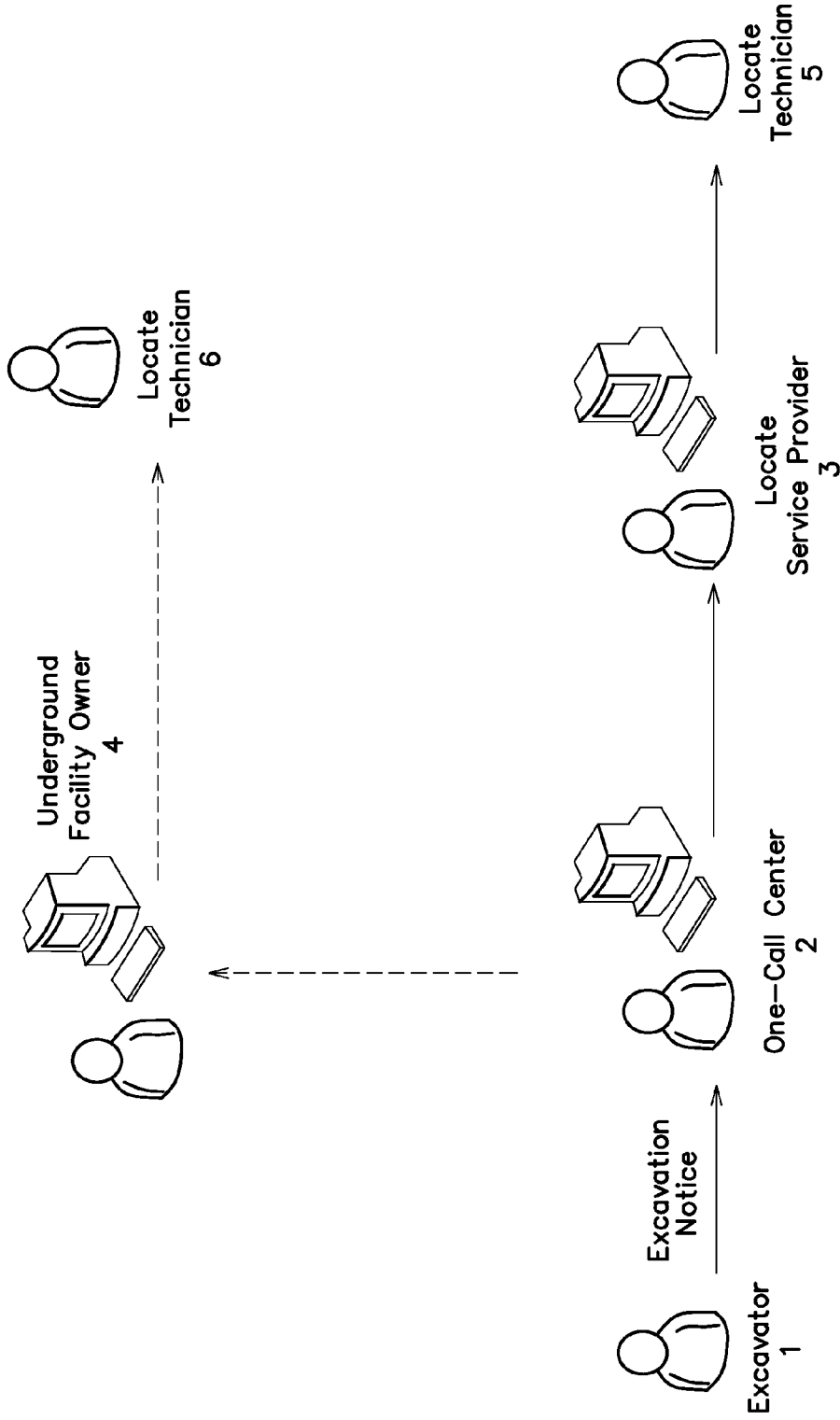

FIG. 1
(Prior Art)

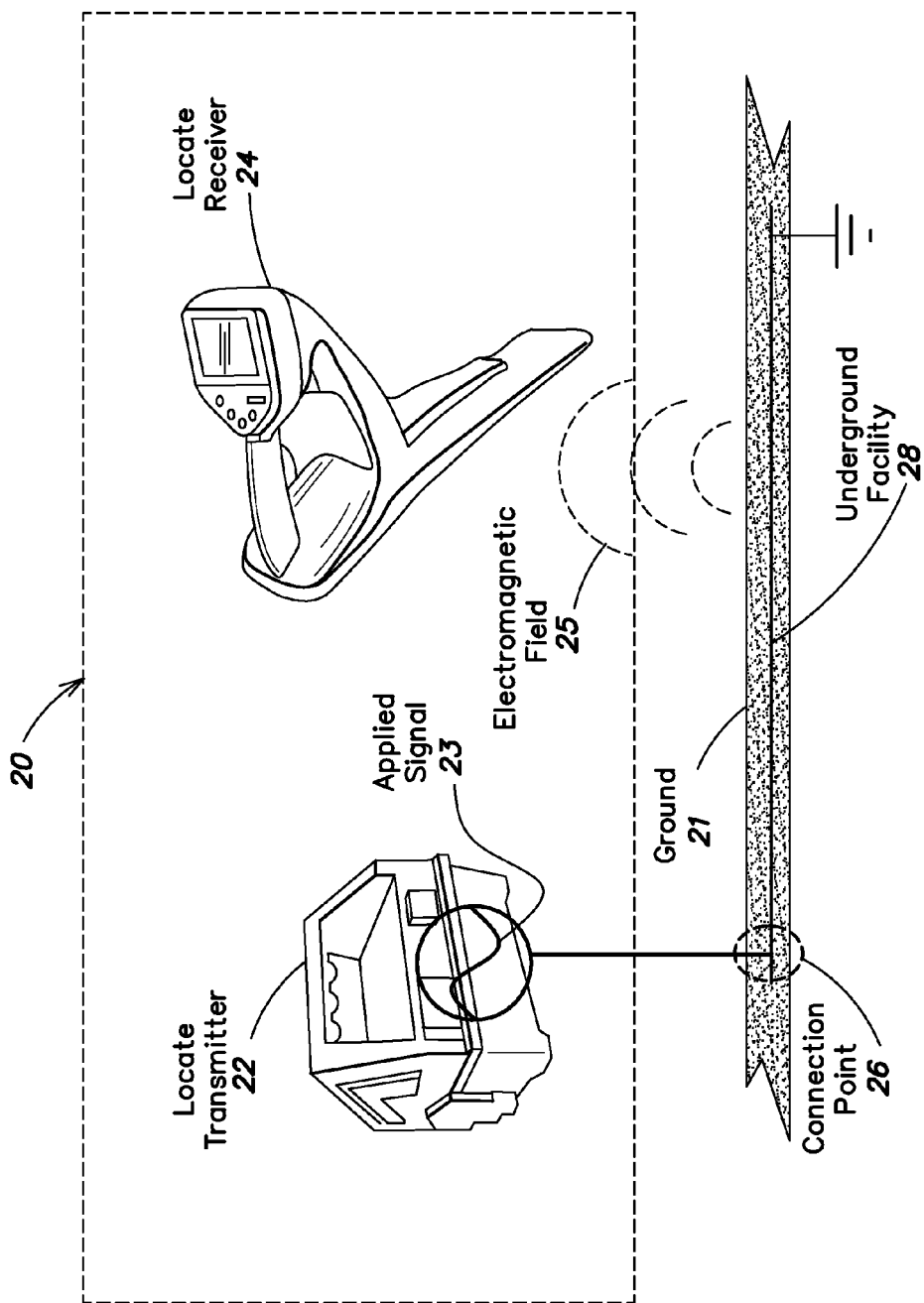

FIG. 2
(Prior Art)

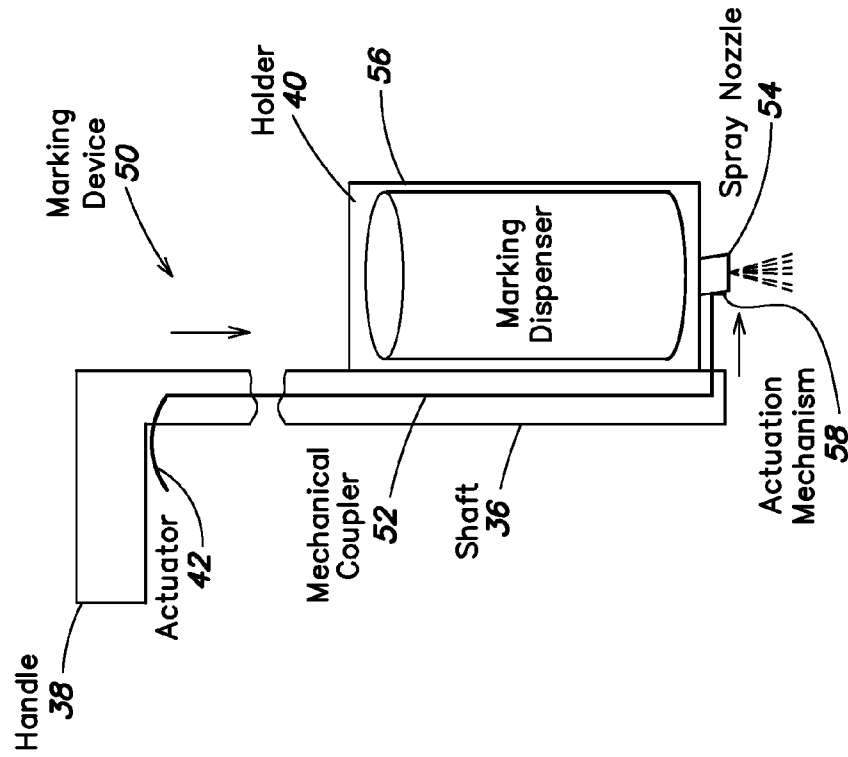

FIG. 3A
(Prior Art)

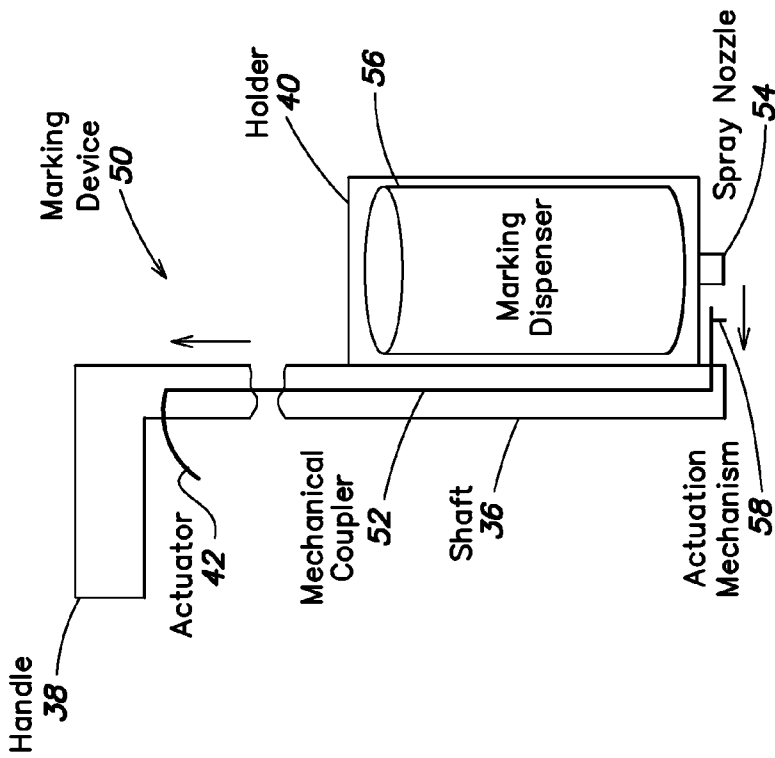

FIG. 3B
(Prior Art)

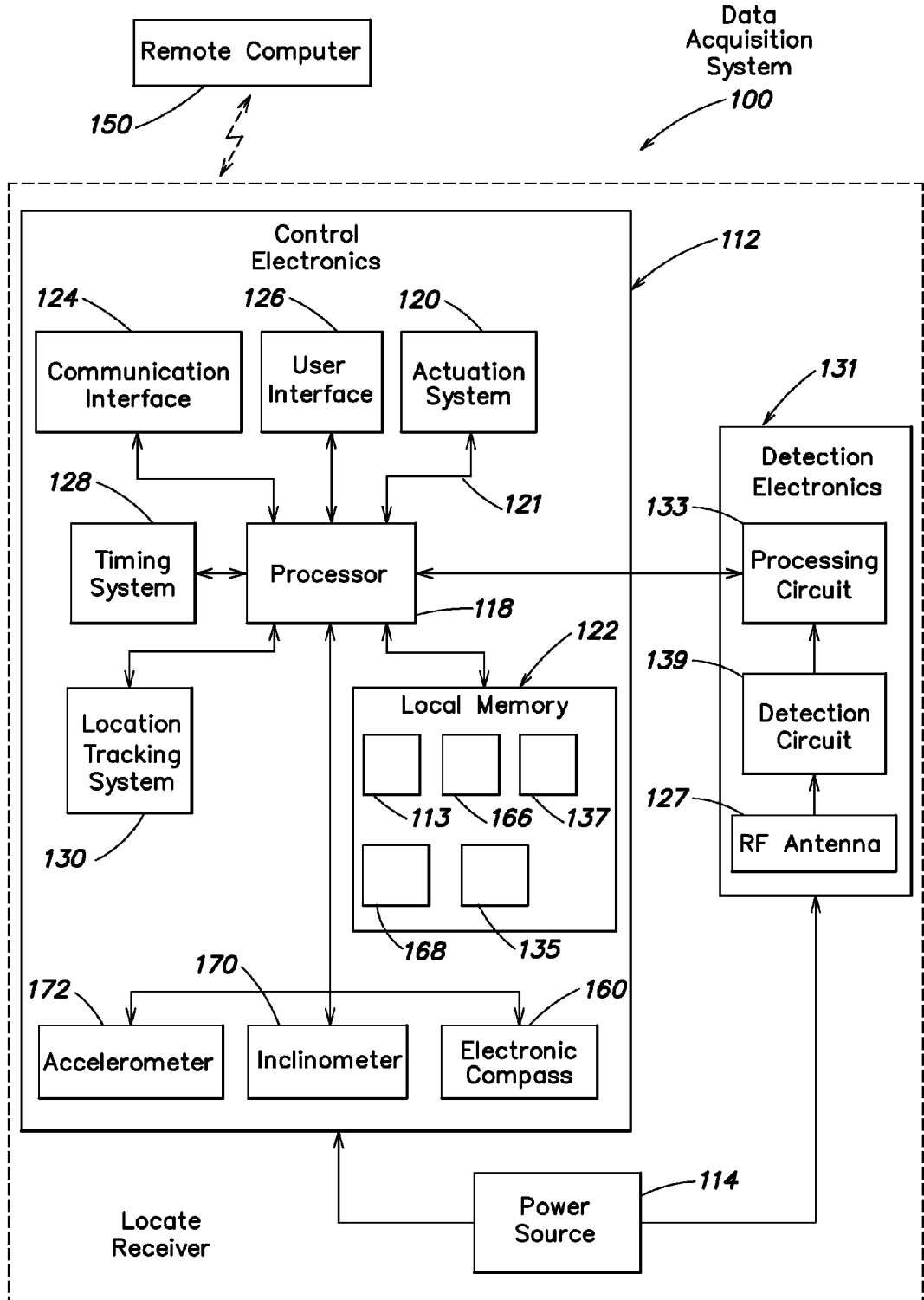

FIG. 4

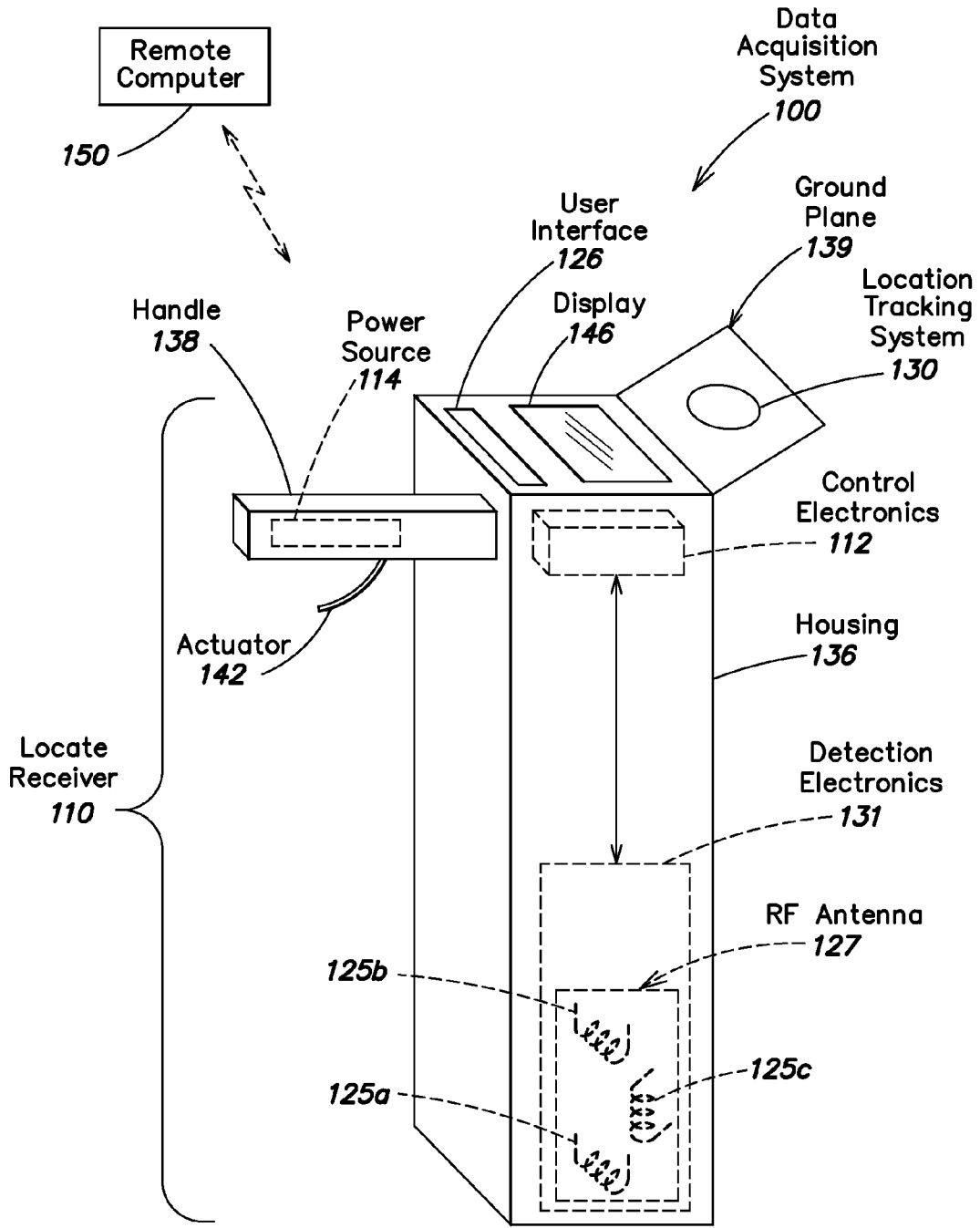

FIG. 5

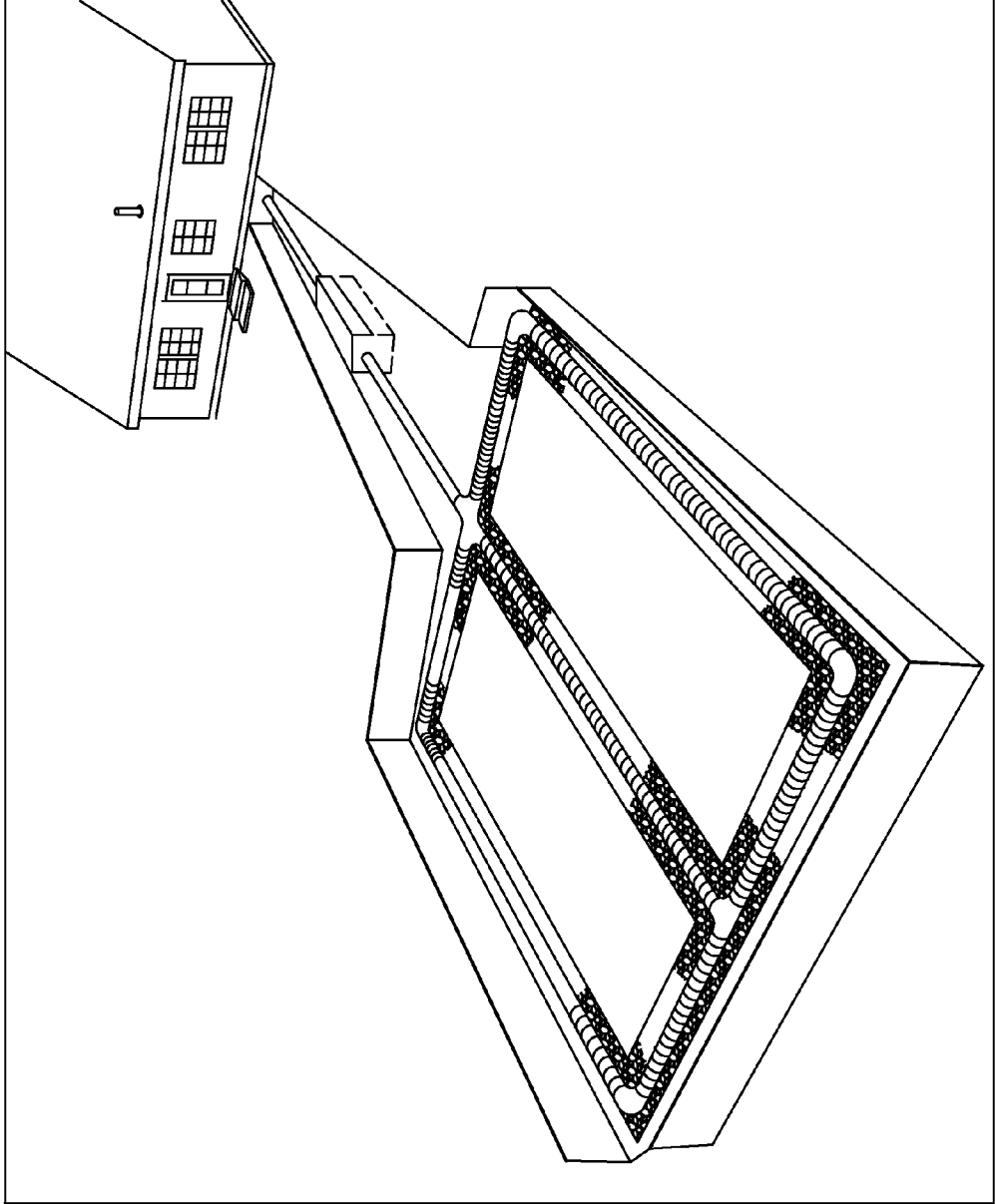

FIG. 7

1000

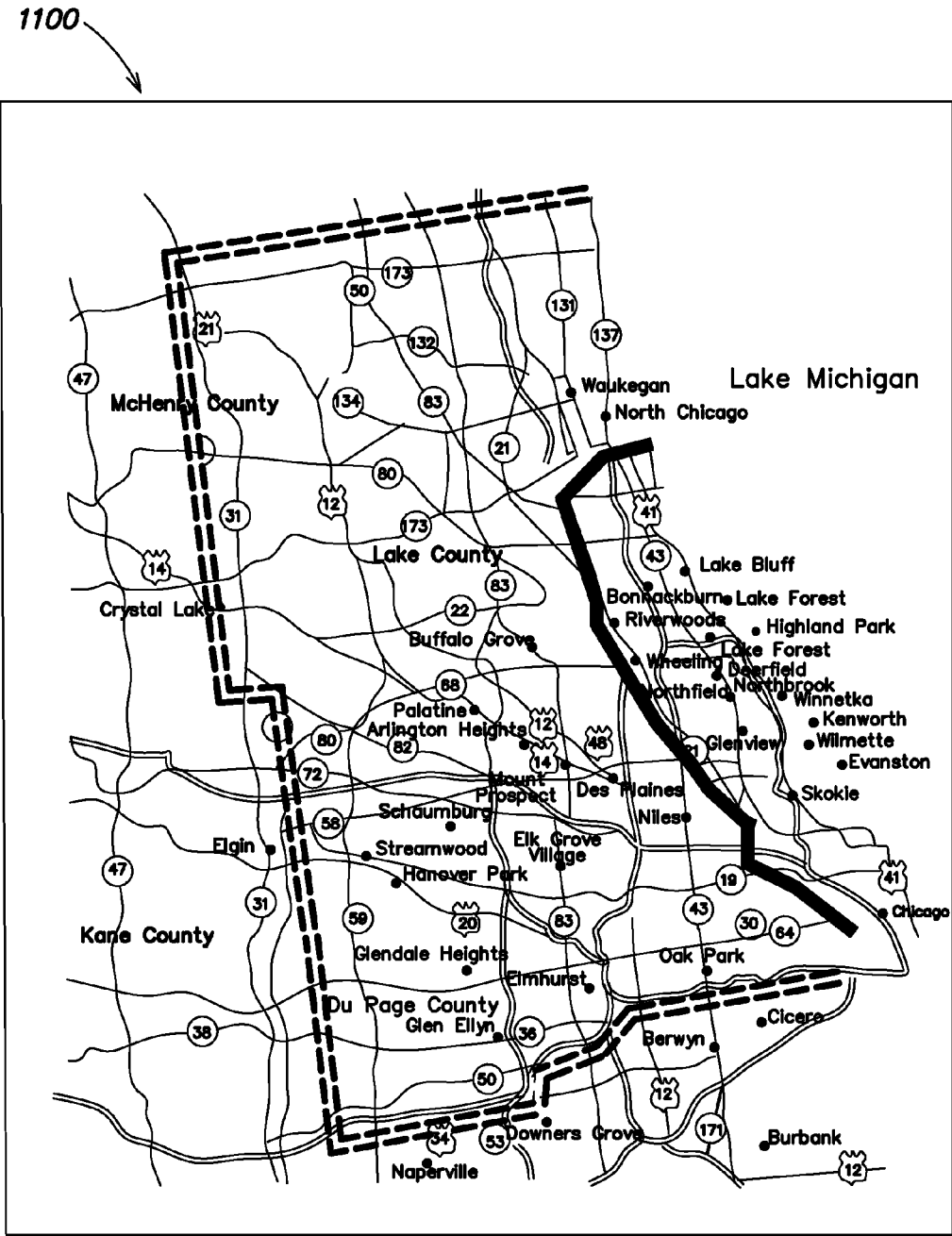

FIG. 8

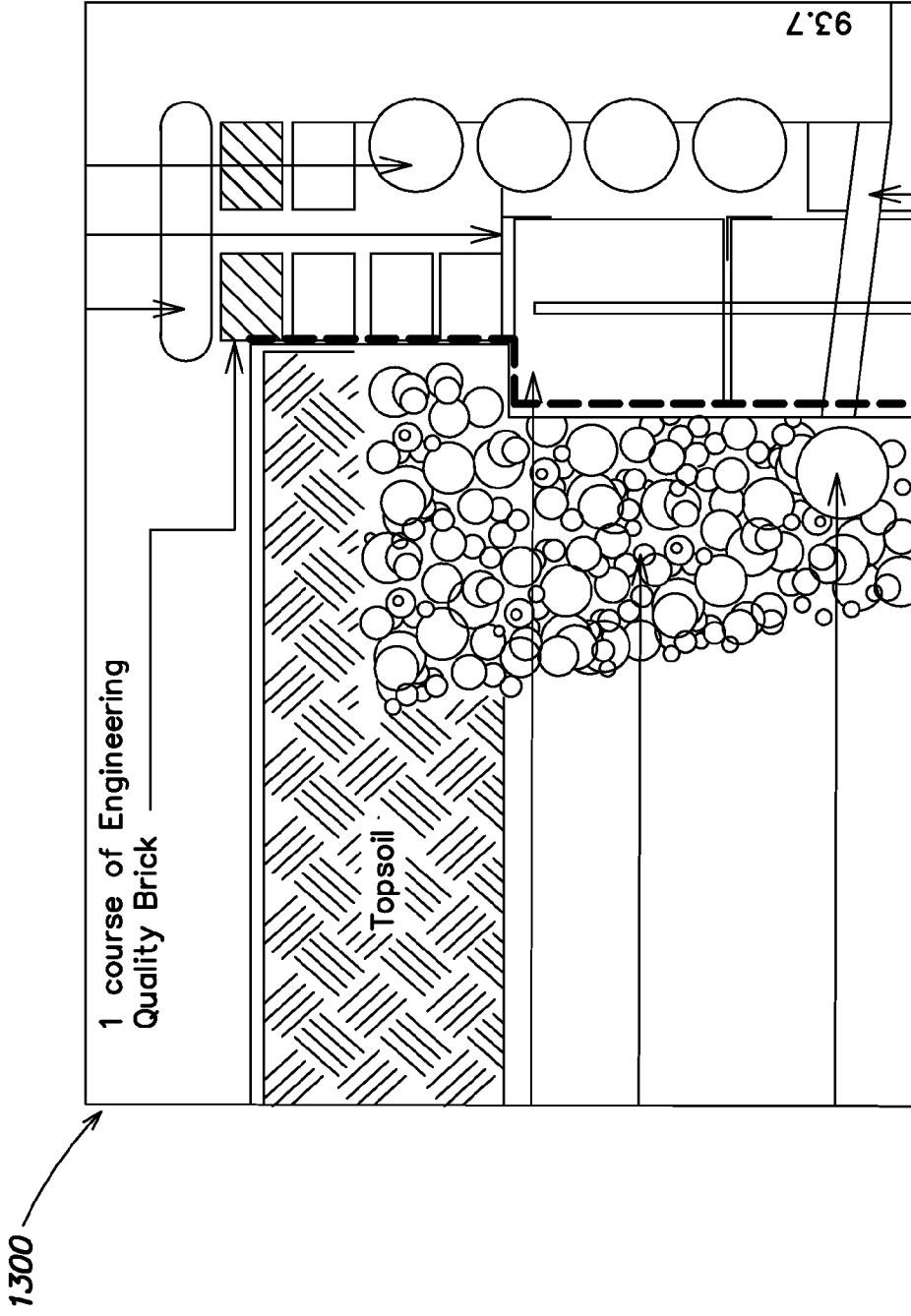

FIG. 9

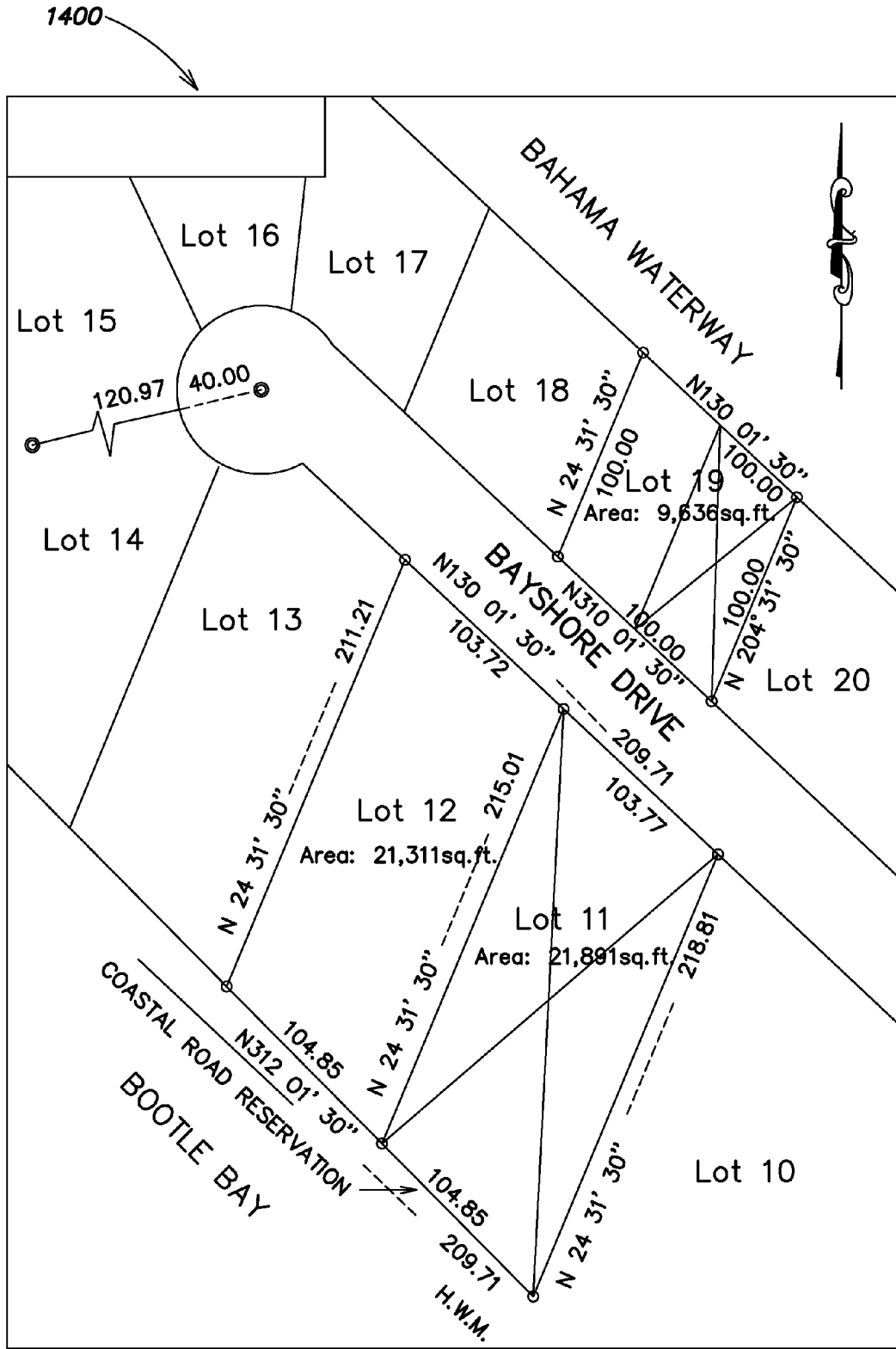

FIG. 10

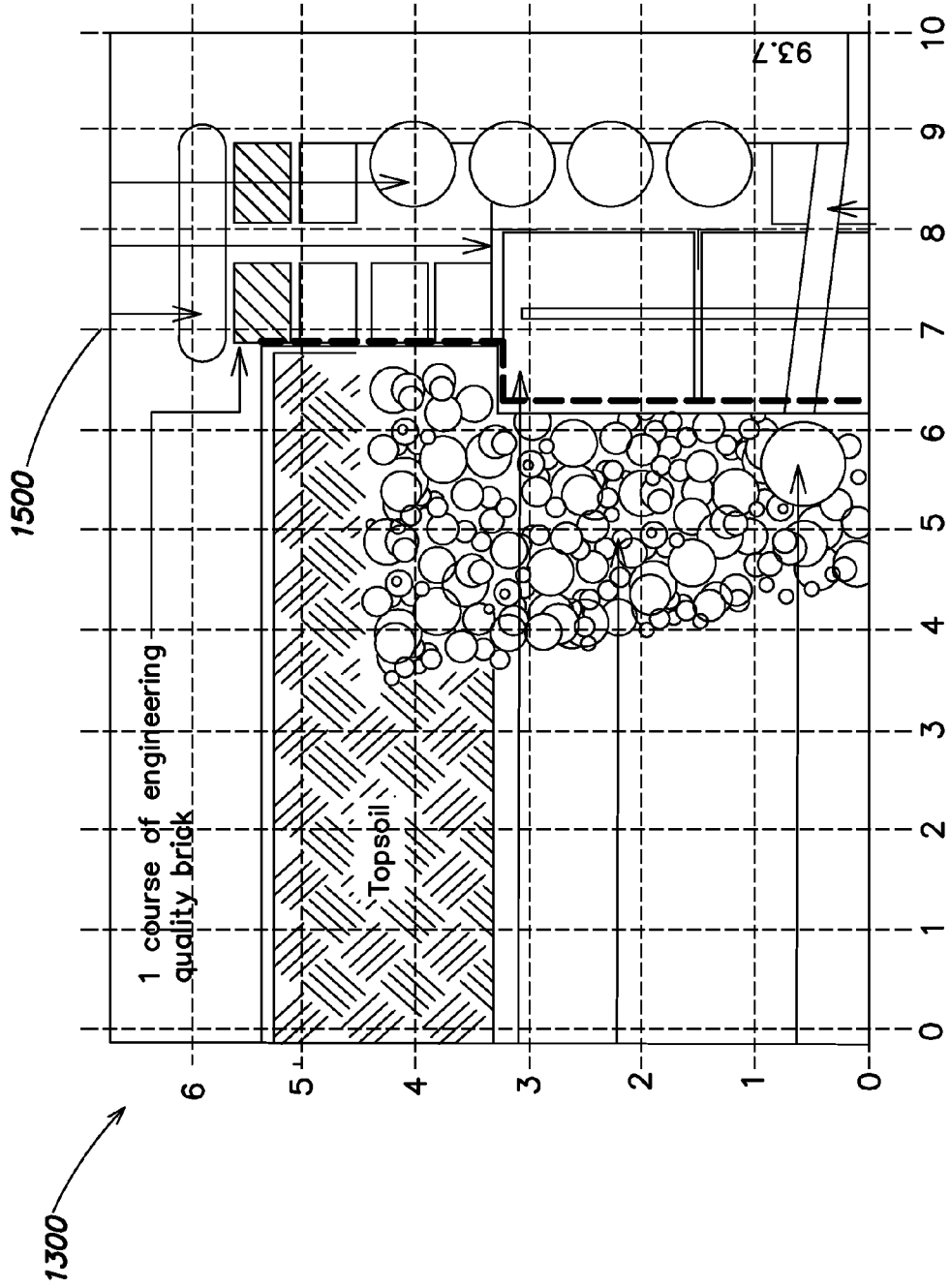

FIG. 11

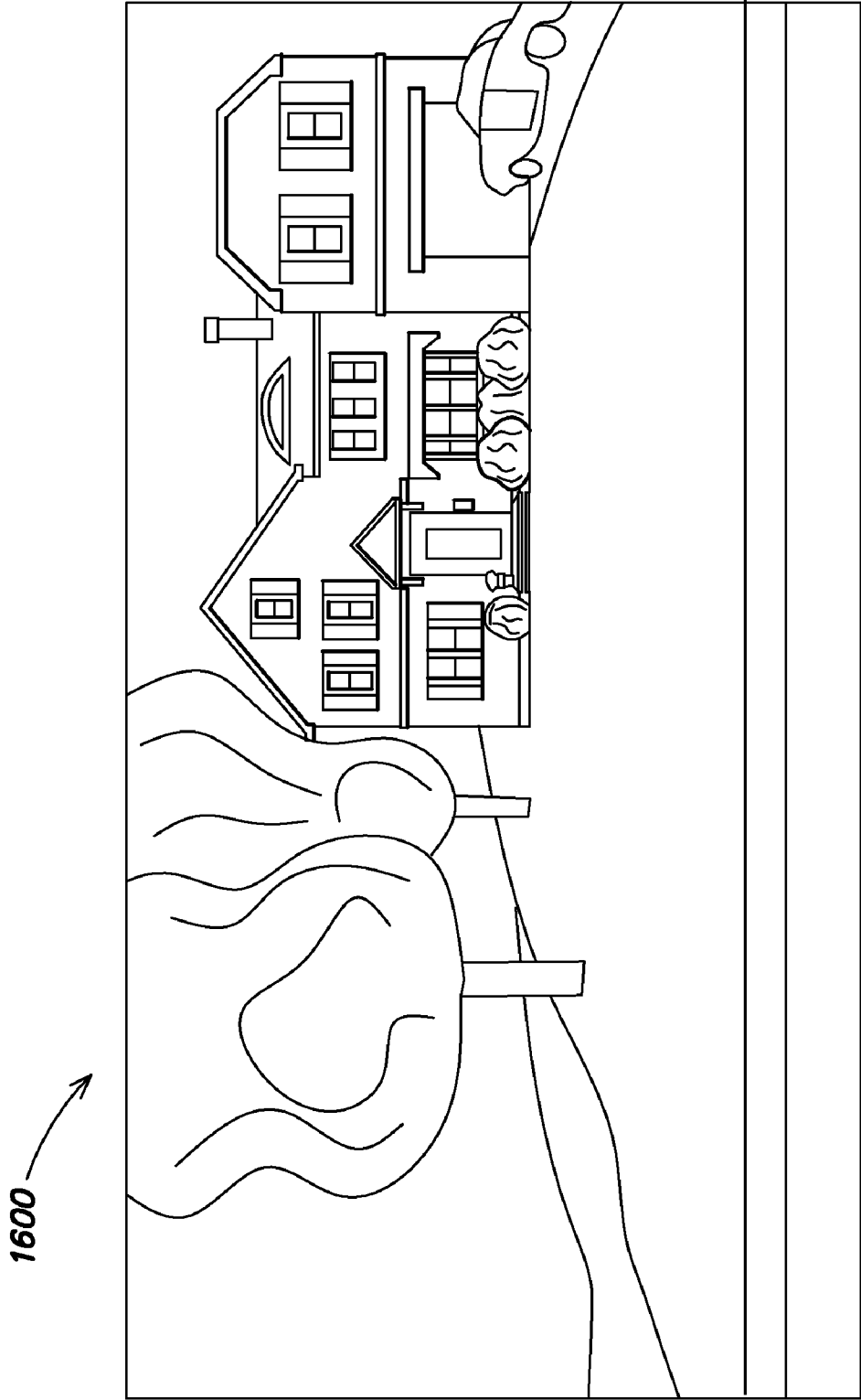

FIG. 12

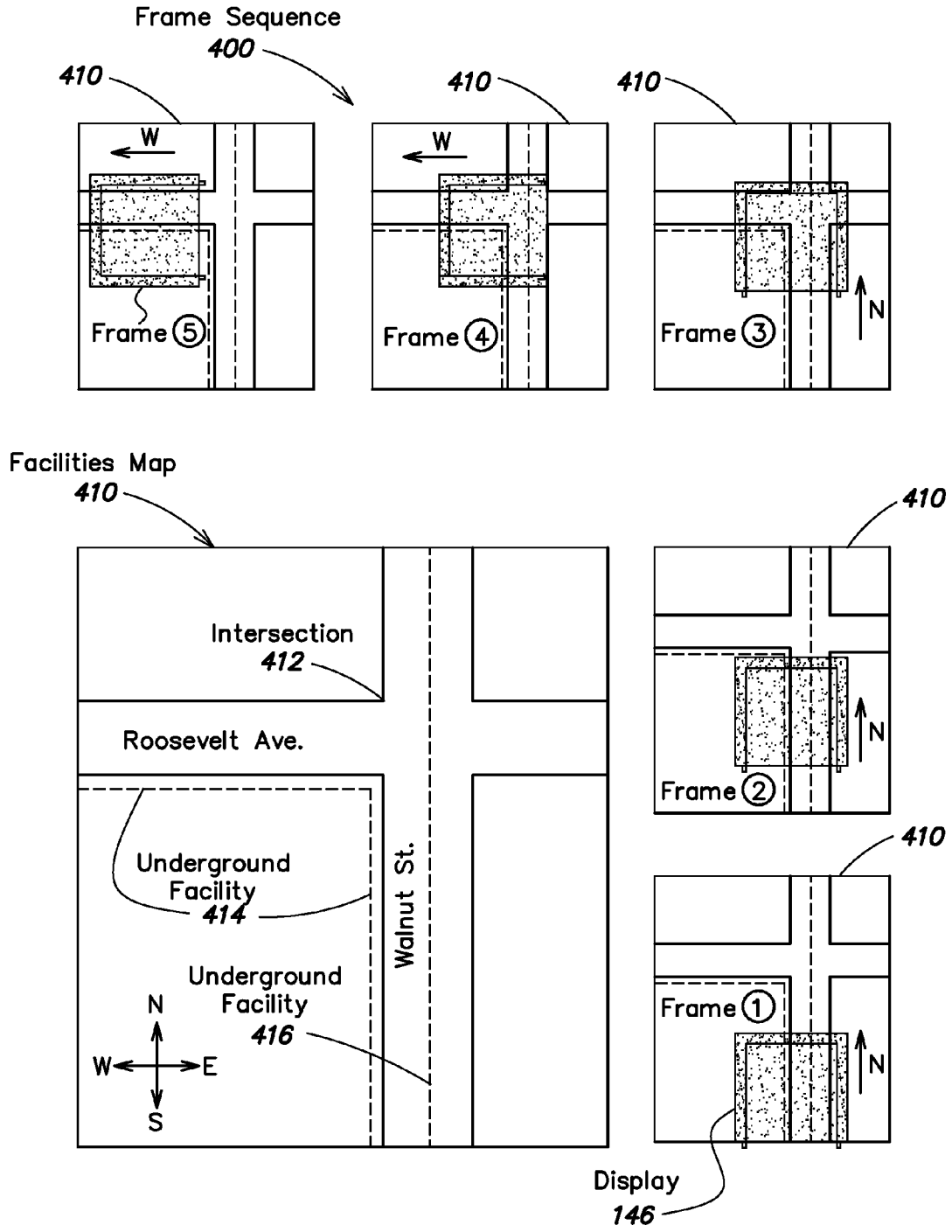

FIG. 13

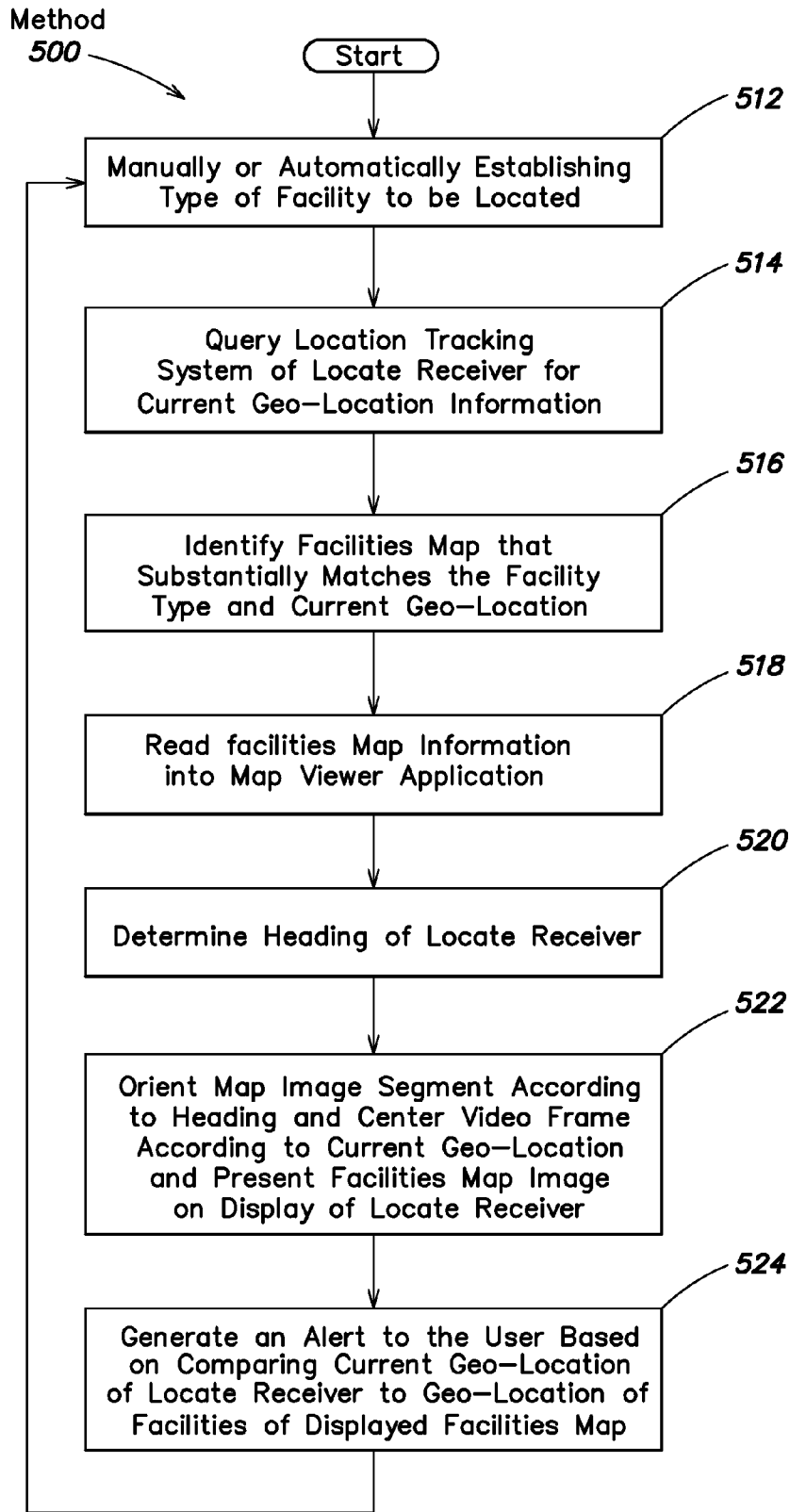

FIG. 14

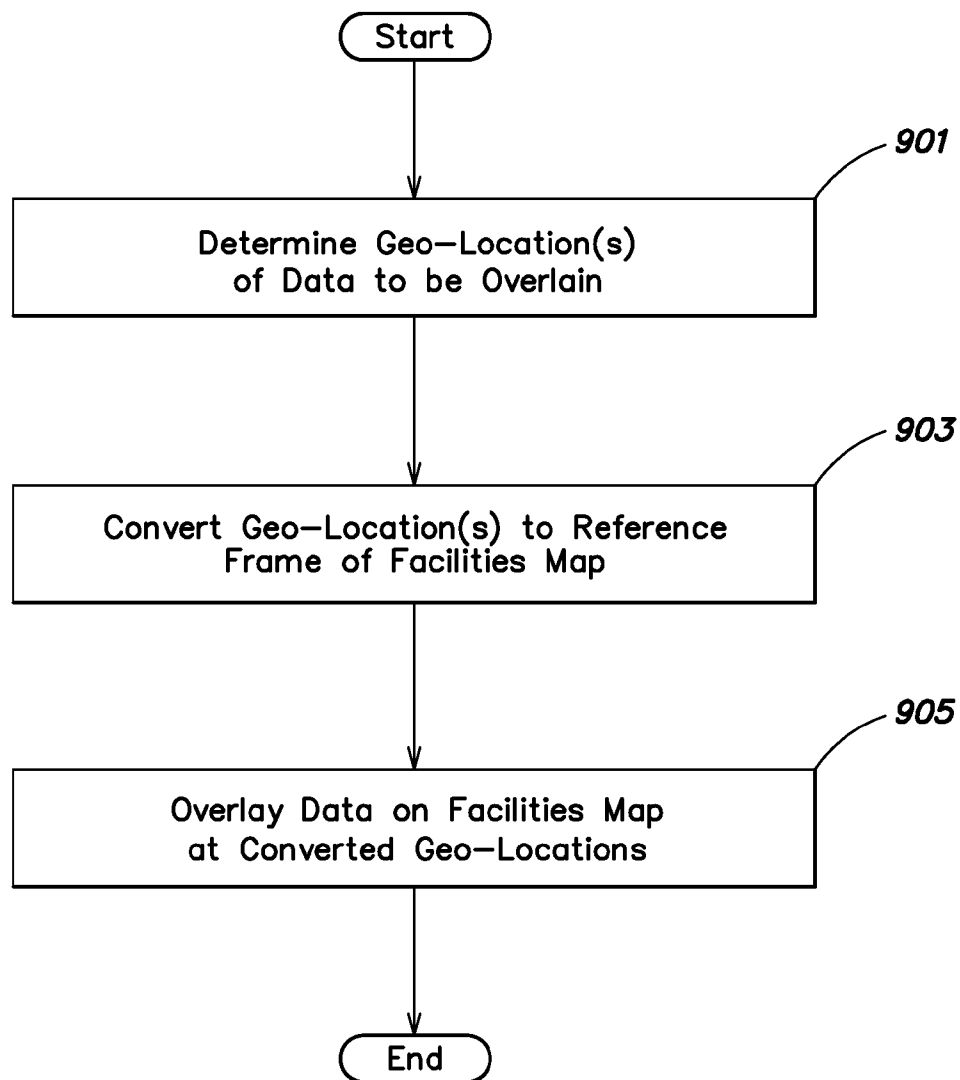

FIG. 15

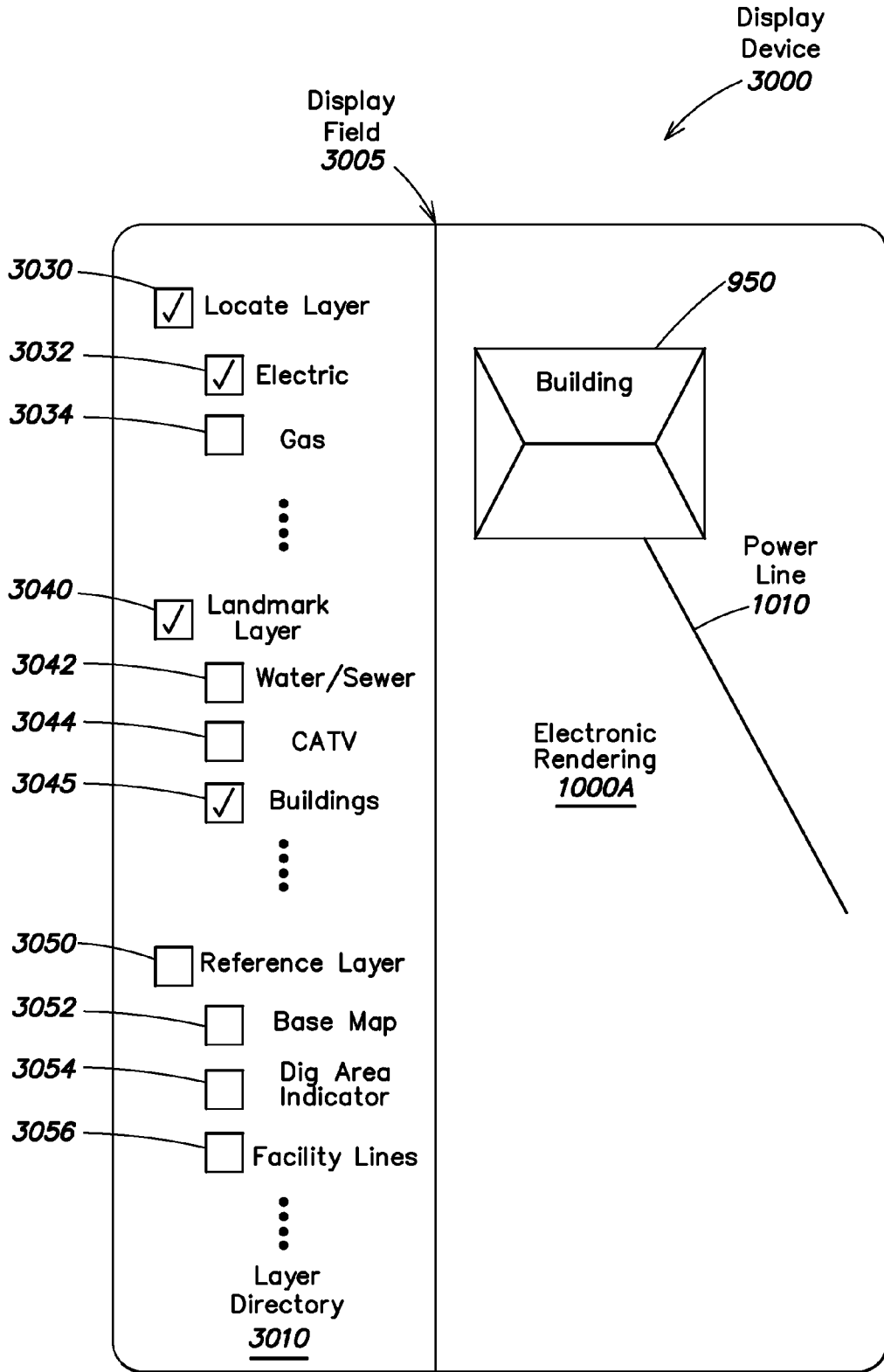

FIG. 16

METHODS AND APPARATUS FOR DISPLAYING AND PROCESSING FACILITIES MAP INFORMATION AND/OR OTHER IMAGE INFORMATION ON A LOCATE DEVICE

CROSS-REFERENCE TO RELATED APPLICATIONS

[0001] This application claims the benefit, under 35 U.S.C. §119(e), of U.S. Provisional Patent Application No. 61/151,568, entitled “Locate Device that has a Mechanism for Viewing Facilities Maps Integrated Therein and Associated Methods,” filed on Feb. 11, 2009 under attorney docket number D0687.70016US00.

[0002] This application claims a priority benefit, under 35 U.S.C. §119(e), of U.S. Provisional Patent Application No. 61/151,778, entitled “Marking Device that has a Ticket Management Mechanism Integrated Therein and Associated Methods,” filed on Feb. 11, 2009 under attorney docket no. D0687.70017US00.

[0003] This application also claims a priority benefit, under 35 U.S.C. §120, as a continuation-in-part (CIP) of U.S. Non-provisional application Ser. No. 12/571,356, entitled, “Method And Apparatus For Analyzing Locate And Marking Operations With Respect To Facilities Maps,” filed on Sep. 30, 2009 under attorney docket no. D0687.70012US01.

[0004] Ser. No. 12/571,356 in turn claims a priority benefit, under 35 U.S.C. §119(e), of U.S. Provisional Patent Application Ser. No. 61/102,169, entitled “Data Acquisition System For And Method Of Analyzing Locate Operations With Respect To Facilities Maps,” filed on Oct. 2, 2008 under attorney docket no. D0687.70012US00.

[0005] This application also claims a priority benefit, under 35 U.S.C. §120, as a continuation-in-part (CIP) of U.S. Non-provisional application Ser. No. 12/649,535, entitled, “Method And Apparatus For Displaying an Electronic Rendering of a Locate and/or Marking Operation Using Display Layers,” filed on Dec. 30, 2009 under attorney docket no. D0687.70010US02.

[0006] This application also claims a priority benefit, under 35 U.S.C. §120, as a continuation-in-part (CIP) of U.S. Non-provisional application Ser. No. 12/571,329, entitled “Methods and Apparatus for Generating Electronic Records of Locate Operations,” filed on Sep. 30, 2009 under attorney docket number D0687.70054US00.

[0007] Ser. No. 12/571,329 in turn claims a priority benefit, under 35 U.S.C. §119(e), of U.S. Provisional Application Ser. No. 61/102,122, entitled “Combination Locate and Marking Device with a Data Acquisition System Installed Therein, and Associated Methods,” filed on Oct. 2, 2008 under attorney docket number D0687.70010US00.

[0008] Each of the above-identified applications is hereby incorporated herein by reference.

BACKGROUND

[0009] Field service operations may be any operation in which companies dispatch technicians and/or other staff to perform certain activities, for example, installations, services and/or repairs. Field service operations may exist in various industries, examples of which include, but are not limited to, network installations, utility installations, security systems, construction, medical equipment, heating, ventilating and air conditioning (HVAC) and the like.

[0010] An example of a field service operation in the construction industry is a so-called “locate and marking operation,” also commonly referred to more simply as a “locate operation” (or sometimes merely as “a locate”). In a typical locate operation, a locate technician visits a work site in which there is a plan to disturb the ground (e.g., excavate, dig one or more holes and/or trenches, bore, etc.) so as to determine a presence or an absence of one or more underground facilities (such as various types of utility cables and pipes) in a dig area to be excavated or disturbed at the work site. In some instances, a locate operation may be requested for a “design” project, in which there may be no immediate plan to excavate or otherwise disturb the ground, but nonetheless information about a presence or absence of one or more underground facilities at a work site may be valuable to inform a planning, permitting and/or engineering design phase of a future construction project.

[0011] In many states, an excavator who plans to disturb ground at a work site is required by law to notify any potentially affected underground facility owners prior to undertaking an excavation activity. Advanced notice of excavation activities may be provided by an excavator (or another party) by contacting a “one-call center.” One-call centers typically are operated by a consortium of underground facility owners for the purposes of receiving excavation notices and in turn notifying facility owners and/or their agents of a plan to excavate. As part of an advanced notification, excavators typically provide to the one-call center various information relating to the planned activity, including a location (e.g., address) of the work site and a description of the dig area to be excavated or otherwise disturbed at the work site.

[0012] FIG. 1 illustrates an example in which a locate operation is initiated as a result of an excavator 1 providing an excavation notice to a one-call center 2. An excavation notice also is commonly referred to as a “locate request,” and may be provided by the excavator to the one-call center via an electronic mail message, information entry via a website maintained by the one-call center, or a telephone conversation between the excavator and a technician at the one-call center. The locate request may include an address or some other location-related information describing the geographic location of a work site at which the excavation is to be performed, as well as a description of the dig area (e.g., a text description), such as its location relative to certain landmarks and/or its approximate dimensions, within which there is a plan to disturb the ground at the work site. One-call centers similarly may receive locate requests for design projects (for which, as discussed above, there may be no immediate plan to excavate or otherwise disturb the ground).

[0013] Using the information provided in a locate request for planned excavation or design projects, the one-call center identifies certain underground facilities that may be present at the indicated work site. For this purpose, many one-call centers typically maintain a collection “polygon maps” which indicate, within a given geographic area over which the one-call center has jurisdiction, generally where underground facilities may be found relative to some geographic reference frame or coordinate system.

[0014] Polygon maps typically are provided to the one-call centers by underground facilities owners within the jurisdiction of the one call center (“members” of the one-call center). A one-call center first provides the facility owner/member with one or more maps (e.g., street or property maps) within the jurisdiction, on which are superimposed some type of grid

or coordinate system employed by the one-call center as a geographic frame of reference. Using the maps provided by the one-call center, the respective facilities owners/members draw one or more polygons on each map to indicate an area within which their facilities generally are disposed underground (without indicating the facilities themselves). These polygons themselves do not precisely indicate geographic locations of respective underground facilities; rather, the area enclosed by a given polygon generally provides an over-inclusive indication of where a given facilities owner's underground facilities are disposed. Different facilities owners/members may draw polygons of different sizes around areas including their underground facilities, and in some instances such polygons can cover appreciably large geographic regions (e.g., an entire subdivision of a residential area), which may further obfuscate the actual/precise location of respective underground facilities.

[0015] Based on the polygon maps collected from the facilities owners/members, the one-call center may in some instances create composite polygon maps to show polygons of multiple different members on a single map. Whether using single member or composite polygon maps, the one-call center examines the address or location information provided in the locate request and identifies a significant buffer zone around an identified work site so as to make an over-inclusive identification of facilities owners/members that may have underground facilities present (e.g., to err on the side of caution). In particular, based on this generally over-inclusive buffer zone around the identified work site (and in some instances significantly over-inclusive buffer zone), the one-call center consults the polygon maps to identify which member polygons intersect with all or a portion of the buffer zone so as to notify these underground facility owners/members and/or their agents of the proposed excavation or design project. Again, it should be appreciated that the buffer zones around an indicated work site utilized by one-call centers for this purpose typically embrace a geographic area that includes but goes well beyond the actual work site, and in many cases the geographic area enclosed by a buffer zone is significantly larger than the actual dig area in which excavation or other similar activities are planned. Similarly, as noted above, the area enclosed by a given member polygon generally does not provide a precise indication of where one or more underground facilities may in fact be found.

[0016] In some instances, one-call centers may also or alternatively have access to various existing maps of underground facilities in their jurisdiction, referred to as "facilities maps." Facilities maps typically are maintained by facilities owners/members within the jurisdiction and show, for respective different utility types, where underground facilities purportedly may be found relative to some geographic reference frame or coordinate system (e.g., a grid, a street or property map, GPS latitude and longitude coordinates, etc.). Facilities maps generally provide somewhat more detail than polygon maps provided by facilities owners/members; however, in some instances the information contained in facilities maps may not be accurate and/or complete. For at least this reason, whether using polygon maps or facilities maps, as noted above the one-call center utilizes a significant buffer zone around an identified work site so as to make an over-inclusive identification of facilities owners/members that may have underground facilities present.

[0017] Once facilities implicated by the locate request are identified by a one-call center (e.g., via the polygon map/

buffer zone process), the one-call center generates a "locate request ticket" (also known as a "locate ticket," or simply a "ticket"). The locate request ticket essentially constitutes an instruction to inspect a work site and typically identifies the work site of the proposed excavation or design and a description of the dig area, typically lists on the ticket all of the underground facilities that may be present at the work site (e.g., by providing a member code for the facility owner whose polygon falls within a given buffer zone), and may also include various other information relevant to the proposed excavation or design (e.g., the name of the excavation company, a name of a property owner or party contracting the excavation company to perform the excavation, etc.). The one-call center sends the ticket to one or more underground facility owners **4** and/or one or more locate service providers **3** (who may be acting as contracted agents of the facility owners) so that they can conduct a locate and marking operation to verify a presence or absence of the underground facilities in the dig area. For example, in some instances, a given underground facility owner **4** may operate its own fleet of locate technicians (e.g., locate technician **6**), in which case the one-call center **2** may send the ticket to the underground facility owner **4**. In other instances, a given facility owner may contract with a locate service provider to receive locate request tickets and perform a locate and marking operation in response to received tickets on their behalf.

[0018] Upon receiving the locate request, a locate service provider or a facility owner (hereafter referred to as a "ticket recipient") may dispatch a locate technician **5** to the work site of planned excavation to determine a presence or absence of one or more underground facilities in the dig area to be excavated or otherwise disturbed. A typical first step for the locate technician **5** includes utilizing an underground facility "locate device," which is an instrument or set of instruments (also referred to commonly as a "locate set") for detecting facilities that are concealed in some manner, such as cables and pipes that are located underground. The locate device is employed by the technician to verify the presence or absence of underground facilities indicated in the locate request ticket as potentially present in the dig area (e.g., via the facility owner member codes listed in the ticket). This process is often referred to as a "locate operation."

[0019] In one example of a locate operation, an underground facility locate device is used to detect electromagnetic fields that are generated by an applied signal provided along a length of a target facility to be identified. In this example, a locate device may include both a signal transmitter to provide the applied signal (e.g., which is coupled by the locate technician to a tracer wire disposed along a length of a facility), and a signal receiver which is generally a hand-held apparatus carried by the locate technician as the technician walks around the dig area to search for underground facilities. FIG. **2** illustrates a conventional locate device **20** (indicated by the dashed box) that includes a transmitter **22** and a locate receiver **24**. The transmitter **22** is connected, via a connection point **26**, to a target object (in this example, underground facility **28**) located in the ground **21**. The transmitter generates the applied signal **23**, which is coupled to the underground facility via the connection point (e.g., to a tracer wire along the facility), resulting in the generation of a magnetic field **25**. The magnetic field in turn is detected by the locate receiver **24**, which itself may include one or more detection antenna (not shown). The locate receiver **24** indicates a presence of a facility when it detects electromagnetic fields aris-

ing from the applied signal **23**. Conversely, the absence of a signal detected by the locate receiver generally indicates the absence of the target facility.

[0020] In yet another example, a locate device employed for a locate operation may include a single instrument, similar in some respects to a conventional metal detector. In particular, such an instrument may include an oscillator to generate an alternating current that passes through a coil, which in turn produces a first magnetic field. If a piece of electrically conductive metal is in close proximity to the coil (e.g., if an underground facility having a metal component is below/near the coil of the instrument), eddy currents are induced in the metal and the metal produces its own magnetic field, which in turn affects the first magnetic field. The instrument may include a second coil to measure changes to the first magnetic field, thereby facilitating detection of metallic objects.

[0021] In addition to the locate operation, the locate technician also generally performs a “marking operation,” in which the technician marks the presence (and in some cases the absence) of a given underground facility in the dig area based on the various signals detected (or not detected) during the locate operation. For this purpose, the locate technician conventionally utilizes a “marking device” to dispense a marking material on, for example, the ground, pavement, or other surface along a detected underground facility. Marking material may be any material, substance, compound, and/or element, used or which may be used separately or in combination to mark, signify, and/or indicate. Examples of marking materials may include, but are not limited to, paint, chalk, dye, and/or iron. Marking devices, such as paint marking wands and/or paint marking wheels, provide a convenient method of dispensing marking materials onto surfaces, such as onto the surface of the ground or pavement.

[0022] FIGS. 3A and 3B illustrate a conventional marking device **50** with a mechanical actuation system to dispense paint as a marker. Generally speaking, the marking device **50** includes a handle **38** at a proximal end of an elongated shaft **36** and resembles a sort of “walking stick,” such that a technician may operate the marking device while standing/walking in an upright or substantially upright position. A marking dispenser holder **40** is coupled to a distal end of the shaft **36** so as to contain and support a marking dispenser **56**, e.g., an aerosol paint can having a spray nozzle **54**. Typically, a marking dispenser in the form of an aerosol paint can is placed into the holder **40** upside down, such that the spray nozzle **54** is proximate to the distal end of the shaft (close to the ground, pavement or other surface on which markers are to be dispensed).

[0023] In FIGS. 3A and 3B, the mechanical actuation system of the marking device **50** includes an actuator or mechanical trigger **42** proximate to the handle **38** that is actuated/triggered by the technician (e.g., via pulling, depressing or squeezing with fingers/hand). The actuator **42** is connected to a mechanical coupler **52** (e.g., a rod) disposed inside and along a length of the elongated shaft **36**. The coupler **52** is in turn connected to an actuation mechanism **58**, at the distal end of the shaft **36**, which mechanism extends outward from the shaft in the direction of the spray nozzle **54**. Thus, the actuator **42**, the mechanical coupler **52**, and the actuation mechanism **58** constitute the mechanical actuation system of the marking device **50**.

[0024] FIG. 3A shows the mechanical actuation system of the conventional marking device **50** in the non-actuated state, wherein the actuator **42** is “at rest” (not being pulled) and, as

a result, the actuation mechanism **58** is not in contact with the spray nozzle **54**. FIG. 3B shows the marking device **50** in the actuated state, wherein the actuator **42** is being actuated (pulled, depressed, squeezed) by the technician. When actuated, the actuator **42** displaced the mechanical coupler **52** and the actuation mechanism **58** such that the actuation mechanism contacts and applies pressure to the spray nozzle **54**, thus causing the spray nozzle to deflect slightly and dispense paint. The mechanical actuation system is spring-loaded so that it automatically returns to the non-actuated state (FIG. 3A) when the actuator **42** is released.

[0025] In some environments, arrows, flags, darts, or other types of physical marks may be used to mark the presence or absence of an underground facility in a dig area, in addition to or as an alternative to a material applied to the ground (such as paint, chalk, dye, tape) along the path of a detected utility. The marks resulting from any of a wide variety of materials and/or objects used to indicate a presence or absence of underground facilities generally are referred to as “locate marks.” Often, different color materials and/or physical objects may be used for locate marks, wherein different colors correspond to different utility types. For example, the American Public Works Association (APWA) has established a standardized color-coding system for utility identification for use by public agencies, utilities, contractors and various groups involved in ground excavation (e.g., red=electric power lines and cables; blue=potable water; orange=telecommunication lines; yellow=gas, oil, steam). In some cases, the technician also may provide one or more marks to indicate that no facility was found in the dig area (sometimes referred to as a “clear”).

[0026] As mentioned above, the foregoing activity of identifying and marking a presence or absence of one or more underground facilities generally is referred to for completeness as a “locate and marking operation.” However, in light of common parlance adopted in the construction industry, and/or for the sake of brevity, one or both of the respective locate and marking functions may be referred to in some instances simply as a “locate operation” or a “locate” (i.e., without making any specific reference to the marking function). Accordingly, it should be appreciated that any reference in the relevant arts to the task of a locate technician simply as a “locate operation” or a “locate” does not necessarily exclude the marking portion of the overall process. At the same time, in some contexts a locate operation is identified separately from a marking operation, wherein the former relates more specifically to detection-related activities and the latter relates more specifically to marking-related activities.

[0027] Inaccurate locating and/or marking of underground facilities can result in physical damage to the facilities, property damage, and/or personal injury during the excavation process that, in turn, can expose a facility owner or contractor to significant legal liability. When underground facilities are damaged and/or when property damage or personal injury results from damaging an underground facility during an excavation, the excavator may assert that the facility was not accurately located and/or marked by a locate technician, while the locate contractor who dispatched the technician may in turn assert that the facility was indeed properly located and marked. Proving whether the underground facility was properly located and marked can be difficult after the excavation (or after some damage, e.g., a gas explosion), because in many cases the physical locate marks (e.g., the marking material or other physical marks used to mark the facility on

the surface of the dig area) will have been disturbed or destroyed during the excavation process (and/or damage resulting from excavation).

SUMMARY

[0028] The inventors have appreciated that, at least in some circumstances, advance knowledge of existing facilities that may be present at a work site/dig area for a proposed excavation may be useful to a technician dispatched to perform a locate and/or marking operation. In this respect, facilities maps may be a valuable resource to the technician; as noted above, facilities maps generally are maintained by various facilities owners and these maps typically indicate the type and geographic location of one or more facility lines (e.g., pipes, cables, and the like) owned and/or operated by the facility owner(s). Although the accuracy of facilities maps may in some cases be suspect (e.g., due to incorrect information in the maps, age of the maps, lack of timely revisions that reflect the current status of deployed facilities, etc.), the various information present in many types of facilities maps generally provides at least some meaningful orientation to the deployment of underground facilities in a given area.

[0029] Accordingly, the inventors have recognized and appreciated that ready access to available facilities maps pertaining to a given work site/dig area may provide the technician with helpful information toward effectively and efficiently conducting a locate and/or marking operation. To this end, a library of facilities maps pertaining to various types of facilities in a given geographic area may be provided to a locate technician dispatched to the field to perform a locate and/or marking operation. For example, a library of appropriate facilities maps may be available for viewing electronically via a computer available at a particular work site (e.g., a laptop computer or other mobile computer disposed in the technician's vehicle). Alternatively, the locate technician may carry with them a set of paper facilities maps in his/her vehicle. The locate technician may review the facilities maps in their vehicle, for example, then proceed to the actual dig area to perform the locate and/or marking operation while attempting to remember relevant information in the facilities maps. However, especially for complex facilities maps, it may be difficult for the technician to commit to memory relevant information in the facilities maps, and it may be inconvenient for the technician to return to the vehicle to consult facilities maps once a locate and/or marking operation has begun.

[0030] In view of the foregoing, various embodiments of the present invention are directed to methods and apparatus for viewing facilities maps information on a locate device used to conduct a locate operation. In this manner, a technician may have access to, and may view locally (e.g., immediately before, during and/or after conducting a locate and/or marking operation in a given work site/dig area), various information derived from facilities maps. For purposes of the present disclosure, and as discussed in greater detail herein, "facilities maps information" refers to any information that may be derived from a facilities map, examples of which information include, but are not limited to, all or a portion of the imagery associated with a facilities map, any underlying metadata (e.g., GIS metadata, facility type information, line or symbol codes, etc.) that may accompany a facilities map or set of facilities maps, and any legend information that may be included in a facilities map.

[0031] In various aspects, the inventive concepts discussed herein generally relate to one of more of the following: 1) selection, from a local or remote library/archive, of one or more appropriate "base" facilities maps, or database(s) of facility map data, relating to a given work site/dig area; 2) manual or automated selection of an appropriate pan and/or zoom (resolution) for displaying, on a user interface/display of a locate device, facilities map information derived from the base facilities map(s); 3) appropriately updating (e.g., changing pan, zoom, orientation, etc.), if/as necessary, displayed facilities map information while a locate device is used during a locate operation; 4) overlaying, on the displayed facilities map information, information relating to the locate operation; and 5) storing locally on the locate device, and/or transmitting from the locate device, facilities map information and/or overlaid locate information (e.g., for further processing, analysis and/or subsequent display).

[0032] Some examples of locate devices configured to collect various information relating specifically to locate operations, which locate devices may be modified according to the inventive concepts described herein to facilitate display of facilities map information, are provided in U.S. non-provisional application Ser. No. 12/571,329, filed Sep. 30, 2009, and entitled "Methods and Apparatus for Generating Electronic Records of Locate Operations," which application is hereby incorporated herein by reference. This application describes, amongst other things, collecting information relating to the geographic location, time, and/or one or more characteristics of a magnetic field detected by one or more receiver antennas of a locate device (e.g., "locate information"), and generating an electronic record based on this collected information. It should be appreciated, however, that the inventive concepts discussed herein in connection with display of facilities map information may be applied generally to various instrumentation/equipment used for one or both of a locate operation and a marking operation (e.g., a marking device, a locate device such as a locate transmitter and/or locate receiver, a combined locate and marking device, etc.), as discussed in further detail below. An example of combined locate and marking device in which the inventive concepts discussed below may be implemented is described in U.S. Non-provisional application Ser. No. 12/569,192, entitled "Methods, Apparatus, and Systems for Generating Electronic Records of Locate and Marking Operations, and Combined Locate and Marking Apparatus for Same," filed on Sep. 29, 2009 under attorney docket no. D0687.70010US01.

[0033] Similarly, it should be appreciated that pursuant to the inventive concepts described herein, facilities map information displayed on a locate device may facilitate execution of either or both of a locate operation and a marking operation, as at least in some instances a technician would have at their disposal, and use together, both a locate device and a marking device to detect and mark a presence or absence of one or more underground facilities at a work site/dig area.

[0034] Furthermore, in addition to facilities map information, it should be appreciated that the present disclosure contemplates other types of image information being accessed and displayed on a user interface/display of a locate device to facilitate various aspects of a locate and/or marking operation. For example, other types of maps (e.g., street/road maps, polygon maps, tax maps, etc.), architectural, construction and/or engineering drawings, land surveys, and photographic renderings/images, and various information derived therefrom, may be displayed on the locate device and may also be

used as the basis for overlaying locate information relating to a locate operation. As with facilities map information, such image information and/or overlaid locate information may be stored locally on the locate device, and/or transmitted from the locate device (e.g., for further processing, analysis and/or subsequent display).

[0035] In sum, one embodiment of the present invention is directed to a locate receiver to detect a presence or an absence of an underground facility. The locate receiver comprises: a housing; an RF antenna for receiving a magnetic field and outputting an output signal; a processing circuit, for receiving the output signal from the RF antenna and determining a magnetic field strength of the magnetic field; a display device coupled to the housing; at least one memory; and at least one processor, coupled to the processing circuit, the display device and the at least one memory, configured to display on the display device a map image that is generated based on first map data selected by the at least one processor.

[0036] Another embodiment is directed to a method for displaying information on a locate receiver having a housing, an RF antenna for receiving a magnetic field and outputting an output signal, a processing circuit, for receiving the output signal from the RF antenna and determining a magnetic field strength of the magnetic field, a display device coupled to the housing, at least one memory; and at least one processor, coupled to the processing circuit, the display device and the at least one memory. The method comprises displaying on the display device a map image that is generated based on first map data selected by the at least one processor.

[0037] Another embodiment is directed to at least one computer-readable storage medium encoded with instructions that, when executed on at least one processor in a locate receiver having a housing, an RF antenna for receiving a magnetic field and outputting an output signal, a processing circuit, for receiving the output signal from the RF antenna and determining a magnetic field strength of the magnetic field, a display device coupled to the housing, at least one memory; and at least one processor, coupled to the processing circuit, the display device and the at least one memory, causes the at least one processor to perform a method comprising: displaying on the display device a map image that is generated based on first map data selected by the at least one processor.

[0038] Another embodiment is directed to a locate receiver to detect a presence or an absence of an underground facility. The locate receiver comprises: a housing; an RF antenna for receiving a magnetic field and outputting an output signal; a processing circuit, for receiving the output signal from the RF antenna and determining a magnetic field strength of the magnetic field; a display device coupled to the housing; at least one memory; and at least one processor, coupled to the processing circuit, the display device and the at least one memory, configured to: display on the display device a map image that is generated based on first map data selected by the at least one processor and that includes a geographic location at which an indication of detection of a facility line was generated; and overlay at least one electronic marking on the first map image at a position on the first map image corresponding to a location at which the indication of detection of a facility line was generated.

[0039] Another embodiment is directed to a method for displaying information on a locate receiver having a housing, an RF antenna for receiving a magnetic field and outputting an output signal, a processing circuit, for receiving the output

signal from the RF antenna and determining a magnetic field strength of the magnetic field, a display device coupled to the housing, at least one memory; and at least one processor, coupled to the processing circuit, the display device and the at least one memory. The method comprises: displaying on the display device a map image that is generated based on first map data selected by the at least one processor and that includes a geographic location at which an indication of detection of a facility line was generated; and overlaying at least one electronic marking on the first map image at a position on the first map image corresponding to a location at which the indication of detection of a facility line was generated.

[0040] Another embodiment is directed to at least one computer-readable storage medium encoded with instructions that, when executed on at least one processor in a locate receiver having a housing, an RF antenna for receiving a magnetic field and outputting an output signal, a processing circuit, for receiving the output signal from the RF antenna and determining a magnetic field strength of the magnetic field, a display device coupled to the housing, at least one memory; and at least one processor, coupled to the processing circuit, the display device and the at least one memory, causes the at least one processor to perform a method comprising: displaying on the display device a map image that is generated based on first map data selected by the at least one processor and that includes a geographic location at which an indication of detection of a facility line was generated; and overlaying at least one electronic marking on the first map image at a position on the first map image corresponding to a location at which the indication of detection of a facility line was generated.

[0041] Another embodiment is directed to a locate receiver to detect a presence or an absence of an underground facility. The locate receiver comprises: a housing; an RF antenna for receiving a magnetic field and outputting an output signal; a processing circuit, for receiving the output signal from the RF antenna and determining a magnetic field strength of the magnetic field; a display device coupled to the housing; at least one memory; and at least one processor, coupled to the processing circuit, the display device and the at least one memory, configured to: display on the display device a map image that is generated based on first map data that comprises facilities map data and is selected by the at least one processor; and compare a location at which an indication of detection of a facility was generated to a location of a facility line as indicated by the first map data and generate an alert based on the comparison.

[0042] Another embodiment is directed to a method for displaying information on a locate receiver having a housing, an RF antenna for receiving a magnetic field and outputting an output signal, a processing circuit, for receiving the output signal from the RF antenna and determining a magnetic field strength of the magnetic field, a display device coupled to the housing, at least one memory; and at least one processor, coupled to the processing circuit, the display device and the at least one memory. The method comprises: displaying on the display device a map image that is generated based on first map data that comprises facilities map data and is selected by the at least one processor; and comparing a location at which an indication of detection of a facility was generated to a location of a facility line as indicated by the first map data and generating an alert based on the comparison.

[0043] Another embodiment is directed to at least one computer-readable storage medium encoded with instructions that, when executed on at least one processor in a locate receiver having a housing, an RF antenna for receiving a magnetic field and outputting an output signal, a processing circuit, for receiving the output signal from the RF antenna and determining a magnetic field strength of the magnetic field, a display device coupled to the housing, at least one memory; and at least one processor, coupled to the processing circuit, the display device and the at least one memory, causes the at least one processor to perform a method comprising: displaying on the display device a map image that is generated based on first map data that comprises facilities map data and is selected by the at least one processor; and comparing a location at which an indication of detection of a facility was generated to a location of a facility line as indicated by the first map data and generating an alert based on the comparison.

[0044] For purposes of the present disclosure, the term “dig area” refers to a specified area of a work site within which there is a plan to disturb the ground (e.g., excavate, dig holes and/or trenches, bore, etc.), and beyond which there is no plan to excavate in the immediate surroundings. Thus, the metes and bounds of a dig area are intended to provide specificity as to where some disturbance to the ground is planned at a given work site. It should be appreciated that a given work site may include multiple dig areas.

[0045] The term “facility” refers to one or more lines, cables, fibers, conduits, transmitters, receivers, or other physical objects or structures capable of or used for carrying, transmitting, receiving, storing, and providing utilities, energy, data, substances, and/or services, and/or any combination thereof. The term “underground facility” means any facility beneath the surface of the ground. Examples of facilities include, but are not limited to, oil, gas, water, sewer, power, telephone, data transmission, cable television (TV), and/or internet services.

[0046] The term “locate device” refers to any apparatus and/or device for detecting and/or inferring the presence or absence of any facility, including without limitation, any underground facility. In various examples, a locate device may include both a locate transmitter and a locate receiver (which in some instances may also be referred to collectively as a “locate instrument set,” or simply “locate set”).

[0047] The term “marking device” refers to any apparatus, mechanism, or other device that employs a marking dispenser for causing a marking material and/or marking object to be dispensed, or any apparatus, mechanism, or other device for electronically indicating (e.g., logging in memory) a location, such as a location of an underground facility. Additionally, the term “marking dispenser” refers to any apparatus, mechanism, or other device for dispensing and/or otherwise using, separately or in combination, a marking material and/or a marking object. An example of a marking dispenser may include, but is not limited to, a pressurized can of marking paint. The term “marking material” means any material, substance, compound, and/or element, used or which may be used separately or in combination to mark, signify, and/or indicate. Examples of marking materials may include, but are not limited to, paint, chalk, dye, and/or iron. The term “marking object” means any object and/or objects used or which may be used separately or in combination to mark, signify, and/or indicate. Examples of marking objects may include, but are not limited to, a flag, a dart, and arrow, and/or an RFID marking ball. It is contemplated that marking material may

include marking objects. It is further contemplated that the terms “marking materials” or “marking objects” may be used interchangeably in accordance with the present disclosure.

[0048] The term “locate mark” means any mark, sign, and/or object employed to indicate the presence or absence of any underground facility. Examples of locate marks may include, but are not limited to, marks made with marking materials, marking objects, global positioning or other information, and/or any other means. Locate marks may be represented in any form including, without limitation, physical, visible, electronic, and/or any combination thereof.

[0049] The terms “actuate” or “trigger” (verb form) are used interchangeably to refer to starting or causing any device, program, system, and/or any combination thereof to work, operate, and/or function in response to some type of signal or stimulus. Examples of actuation signals or stimuli may include, but are not limited to, any local or remote, physical, audible, inaudible, visual, non-visual, electronic, mechanical, electromechanical, biomechanical, biosensing or other signal, instruction, or event. The terms “actuator” or “trigger” (noun form) are used interchangeably to refer to any method or device used to generate one or more signals or stimuli to cause or causing actuation. Examples of an actuator/trigger may include, but are not limited to, any form or combination of a lever, switch, program, processor, screen, microphone for capturing audible commands, and/or other device or method. An actuator/trigger may also include, but is not limited to, a device, software, or program that responds to any movement and/or condition of a user, such as, but not limited to, eye movement, brain activity, heart rate, other data, and/or the like, and generates one or more signals or stimuli in response thereto. In the case of a marking device or other marking mechanism (e.g., to physically or electronically mark a facility or other feature), actuation may cause marking material to be dispensed, as well as various data relating to the marking operation (e.g., geographic location, time stamps, characteristics of material dispensed, etc.) to be logged in an electronic file stored in memory. In the case of a locate device or other locate mechanism (e.g., to physically locate a facility or other feature), actuation may cause a detected signal strength, signal frequency, depth, or other information relating to the locate operation to be logged in an electronic file stored in memory.

[0050] The terms “locate and marking operation,” “locate operation,” and “locate” generally are used interchangeably and refer to any activity to detect, infer, and/or mark the presence or absence of an underground facility. In some contexts, the term “locate operation” is used to more specifically refer to detection of one or more underground facilities, and the term “marking operation” is used to more specifically refer to using a marking material and/or one or more marking objects to mark a presence or an absence of one or more underground facilities. The term “locate technician” refers to an individual performing a locate operation. A locate and marking operation often is specified in connection with a dig area, at least a portion of which may be excavated or otherwise disturbed during excavation activities.

[0051] The term “user” refers to an individual utilizing a locate device and/or a marking device and may include, but is not limited to, land surveyors, locate technicians, and support personnel.

[0052] The terms “locate request” and “excavation notice” are used interchangeably to refer to any communication to request a locate and marking operation. The term “locate

request ticket” (or simply “ticket”) refers to any communication or instruction to perform a locate operation. A ticket might specify, for example, the address or description of a dig area to be marked, the day and/or time that the dig area is to be marked, and/or whether the user is to mark the excavation area for certain gas, water, sewer, power, telephone, cable television, and/or some other underground facility. The term “historical ticket” refers to past tickets that have been completed.

[0053] The following U.S. published applications and patents are hereby incorporated herein by reference:

[0054] U.S. Pat. No. 7,640,105, issued Dec. 29, 2009, filed Mar. 13, 2007, and entitled “Marking System and Method With Location and/or Time Tracking;”

[0055] U.S. publication no. 2008-0245299-A1, published Oct. 9, 2008, filed Apr. 4, 2007, and entitled “Marking System and Method;”

[0056] U.S. publication no. 2009-0013928-A1, published Jan. 15, 2009, filed Sep. 24, 2008, and entitled “Marking System and Method;”

[0057] U.S. publication no. 2009-0238414-A1, published Sep. 24, 2009, filed Mar. 18, 2008, and entitled “Virtual White Lines for Delimiting Planned Excavation Sites;”

[0058] U.S. publication no. 2009-0241045-A1, published Sep. 24, 2009, filed Sep. 26, 2008, and entitled “Virtual White Lines for Delimiting Planned Excavation Sites;”

[0059] U.S. publication no. 2009-0238415-A1, published Sep. 24, 2009, filed Sep. 26, 2008, and entitled “Virtual White Lines for Delimiting Planned Excavation Sites;”

[0060] U.S. publication no. 2009-0241046-A1, published Sep. 24, 2009, filed Jan. 16, 2009, and entitled “Virtual White Lines for Delimiting Planned Excavation Sites;”

[0061] U.S. publication no. 2009-0238416-A1, published Sep. 24, 2009, filed Jan. 16, 2009, and entitled “Virtual White Lines for Delimiting Planned Excavation Sites;”

[0062] U.S. publication no. 2009-0237408-A1, published Sep. 24, 2009, filed Jan. 16, 2009, and entitled “Virtual White Lines for Delimiting Planned Excavation Sites;”

[0063] U.S. publication no. 2009-0202101-A1, published Aug. 13, 2009, filed Feb. 12, 2008, and entitled “Electronic Manifest of Underground Facility Locate Marks;”

[0064] U.S. publication no. 2009-0202110-A1, published Aug. 13, 2009, filed Sep. 11, 2008, and entitled “Electronic Manifest of Underground Facility Locate Marks;”

[0065] U.S. publication no. 2009-0201311-A1, published Aug. 13, 2009, filed Jan. 30, 2009, and entitled “Electronic Manifest of Underground Facility Locate Marks;”

[0066] U.S. publication no. 2009-0202111-A1, published Aug. 13, 2009, filed Jan. 30, 2009, and entitled “Electronic Manifest of Underground Facility Locate Marks;”

[0067] U.S. publication no. 2009-0204625-A1, published Aug. 13, 2009, filed Feb. 5, 2009, and entitled “Electronic Manifest of Underground Facility Locate Operation;”

[0068] U.S. publication no. 2009-0204466-A1, published Aug. 13, 2009, filed Sep. 4, 2008, and entitled “Ticket Approval System For and Method of Performing Quality Control In Field Service Applications;”

[0069] U.S. publication no. 2009-0207019-A1, published Aug. 20, 2009, filed Apr. 30, 2009, and entitled “Ticket Approval System For and Method of Performing Quality Control In Field Service Applications;”

[0070] U.S. publication no. 2009-0210284-A1, published Aug. 20, 2009, filed Apr. 30, 2009, and entitled “Ticket

Approval System For and Method of Performing Quality Control In Field Service Applications;”

[0071] U.S. publication no. 2009-0210297-A1, published Aug. 20, 2009, filed Apr. 30, 2009, and entitled “Ticket Approval System For and Method of Performing Quality Control In Field Service Applications;”

[0072] U.S. publication no. 2009-0210298-A1, published Aug. 20, 2009, filed Apr. 30, 2009, and entitled “Ticket Approval System For and Method of Performing Quality Control In Field Service Applications;”

[0073] U.S. publication no. 2009-0210285-A1, published Aug. 20, 2009, filed Apr. 30, 2009, and entitled “Ticket Approval System For and Method of Performing Quality Control In Field Service Applications;”

[0074] U.S. publication no. 2009-0324815-A1, published Dec. 31, 2009, filed Apr. 24, 2009, and entitled “Marking Apparatus and Marking Methods Using Marking Dispenser with Machine-Readable ID Mechanism;”

[0075] U.S. publication no. 2010-0006667-A1, published Jan. 14, 2010, filed Apr. 24, 2009, and entitled, “Marker Detection Mechanisms for use in Marking Devices And Methods of Using Same;”

[0076] U.S. publication no. 2009-0204238-A1, published Aug. 13, 2009, filed Feb. 2, 2009, and entitled “Electronically Controlled Marking Apparatus and Methods;”

[0077] U.S. publication no. 2009-0208642-A1, published Aug. 20, 2009, filed Feb. 2, 2009, and entitled “Marking Apparatus and Methods For Creating an Electronic Record of Marking Operations;”

[0078] U.S. publication no. 2009-0210098-A1, published Aug. 20, 2009, filed Feb. 2, 2009, and entitled “Marking Apparatus and Methods For Creating an Electronic Record of Marking Apparatus Operations;”

[0079] U.S. publication no. 2009-0201178-A1, published Aug. 13, 2009, filed Feb. 2, 2009, and entitled “Methods For Evaluating Operation of Marking Apparatus;”

[0080] U.S. publication no. 2009-0238417-A1, published Sep. 24, 2009, filed Feb. 6, 2009, and entitled “Virtual White Lines for Indicating Planned Excavation Sites on Electronic Images;”

[0081] U.S. publication no. 2009-0202112-A1, published Aug. 13, 2009, filed Feb. 11, 2009, and entitled “Searchable Electronic Records of Underground Facility Locate Marking Operations;”

[0082] U.S. publication no. 2009-0204614-A1, published Aug. 13, 2009, filed Feb. 11, 2009, and entitled “Searchable Electronic Records of Underground Facility Locate Marking Operations;”

[0083] U.S. publication no. 2009-0327024-A1, published Dec. 31, 2009, filed Jun. 26, 2009, and entitled “Methods and Apparatus for Quality Assessment of a Field Service Operation;”

[0084] U.S. publication no. 2010-0010862-A1, published Jan. 14, 2010, filed Aug. 7, 2009, and entitled, “Methods and Apparatus for Quality Assessment of a Field Service Operation Based on Geographic Information;”

[0085] U.S. publication No. 2010-0010863-A1, published Jan. 14, 2010, filed Aug. 7, 2009, and entitled, “Methods and Apparatus for Quality Assessment of a Field Service Operation Based on Multiple Scoring Categories;”

[0086] U.S. publication no. 2010-0010882-A1, published Jan. 14, 2010, filed Aug. 7, 2009, and entitled, “Methods and Apparatus for Quality Assessment of a Field Service Operation Based on Dynamic Assessment Parameters;” and

[0087] U.S. publication no. 2010-0010883-A1, published Jan. 14, 2010, filed Aug. 7, 2009, and entitled, "Methods and Apparatus for Quality Assessment of a Field Service Operation Based on Multiple Quality Assessment Criteria."

[0088] It should be appreciated that all combinations of the foregoing concepts and additional concepts discussed in greater detail below (provided such concepts are not mutually inconsistent) are contemplated as being part of the inventive subject matter disclosed herein. In particular, all combinations of claimed subject matter appearing at the end of this disclosure are contemplated as being part of the inventive subject matter disclosed herein. It should also be appreciated that terminology explicitly employed herein that also may appear in any disclosure incorporated by reference should be accorded a meaning most consistent with the particular concepts disclosed herein.

BRIEF DESCRIPTION OF THE DRAWINGS

[0089] The drawings are not necessarily to scale, emphasis instead generally being placed upon illustrating the principles of the invention.

[0090] FIG. 1 shows an example in which a locate and marking operation is initiated as a result of an excavator providing an excavation notice to a one-call center.

[0091] FIG. 2 illustrates one example of a conventional locate instrument set including a locate transmitter and a locate receiver.

[0092] FIGS. 3A and 3B illustrate a conventional marking device in an actuated and non-actuated state, respectively.

[0093] FIG. 4 is a functional block diagram of a data acquisition system including a locate device for creating electronic records of located operations and displaying facilities map information, according to some embodiments of the present invention.

[0094] FIG. 5 is a perspective view of the data acquisition system of FIG. 4, illustrating an exemplary locate device upon which some embodiments of the invention may be implemented.

[0095] FIG. 6 illustrates an example of facilities map information that may be viewed on the display of the locate device shown in FIGS. 4 and 5;

[0096] FIG. 7 illustrates a sketch representing an exemplary input image that may be viewed on the display of the locate device.

[0097] FIG. 8 illustrates a map, representing an exemplary input image that may be viewed on the display of the locate device.

[0098] FIG. 9 illustrates a construction/engineering drawing, representing an exemplary input image that may be viewed on the display of the locate device.

[0099] FIG. 10 illustrates a land survey map, representing an exemplary input image that may be viewed on the display of the locate device.

[0100] FIG. 11 illustrates a grid, overlaid on the construction/engineering drawing of FIG. 9, representing an exemplary input image that may be viewed on the display of the locate device.

[0101] FIG. 12 illustrates a street level image, representing an exemplary input image that may be viewed on the display of the locate device.

[0102] FIG. 13 illustrates an example of a video frame sequence of a facilities map that may be displayed on the display of a locate device, in accordance with some embodiments.

[0103] FIG. 14 illustrates a flow diagram of a process for displaying a facilities map on the display of a locate device, in accordance with some embodiments.

[0104] FIG. 15 illustrates a flow diagram of a process for overlaying data on a facilities map displayed on the display of a locate device.

[0105] FIG. 16 shows a display device having a display field in which one or more display layers and/or sub-layers of locate information, landmark information and/or image/reference information may be selectively enabled or disabled for display, according to one embodiment of the present invention.

DETAILED DESCRIPTION

[0106] Following below are more detailed descriptions of various concepts related to, and embodiments of, inventive systems, methods and apparatus for viewing facilities maps information and/or other image information on a locate device. It should be appreciated that various concepts introduced above and discussed in greater detail below may be implemented in any of numerous ways, as the disclosed concepts are not limited to any particular manner of implementation. Examples of specific implementations and applications are provided primarily for illustrative purposes.

[0107] Various embodiments of the present invention relate to a locate device capable of accessing and displaying various types of information derived from one or more facilities maps. In some embodiments, the locate device may have the capability to access one or more locally and/or remotely stored electronic facilities maps or a database of facility map information, and select and display all or a portion of a facilities map that is of interest to a technician or other technician of the locate device. As explained in detail below, in some embodiments, the locate device may update the display of the facilities map information in essentially real-time (e.g., change one or more of pan, zoom, orientation, etc.), as the locate device is in use, when changes in the geo-location and/or heading of the locate device are detected. In this manner, the locate device provides a convenient way for the locate technician to view and interact with facilities map information in real-time while conducting a locate and/or marking operation (and/or immediately before or after the locate operation).

[0108] In various aspects, the inventive concepts discussed herein generally relate to one of more of the following: 1) selection, from a local or remote library/archive, of one or more appropriate "base" facilities maps or facilities map data sets relating to a given work site/dig area; 2) manual or automated selection of an appropriate pan and/or zoom (resolution) for displaying, on a user interface/display of a locate device, facilities map information derived from the base facilities map(s); 3) appropriately updating, if/as necessary, displayed facilities map information while a locate device is used during a locate operation; 4) overlaying, on the displayed facilities map information, information relating to the locate operation; and 5) storing locally on the locate device, and/or transmitting from the locate device, facilities map information and/or overlaid locate information (e.g., for further processing, analysis and/or subsequent display).

[0109] Furthermore, in addition to facilities map information, it should be appreciated that the present disclosure contemplates other types of image information being accessed and displayed on a user interface/display of a locate device to facilitate various aspects of a locate and/or marking opera-

tion. For example, other types of maps (e.g., street/road maps, polygon maps, tax maps, etc.), architectural, construction and/or engineering drawings, land surveys, and photographic renderings/images, and various information derived therefrom, including virtual white line (VWL) designations that delimit, on a map or other image, a planned excavation area, may be displayed on the locate device and may also be used as the basis for overlaying locate information relating to a locate operation.

I. LOCATE DEVICES

[0110] As discussed above a locate device (or so-called “locate set”) may include at least one transmitter and a locate receiver. In one embodiment of the present invention, one or both of a locate transmitter and a locate receiver may be particularly configured to acquire locate information relating to a locate operation, generate an electronic record of the acquired locate information, and store, transmit, analyze or otherwise process the acquired locate information. Such locate devices also may be configured to access and display facilities map information to facilitate the locate operation.

[0111] Various types of locate information may be generated during, or otherwise associated with, the use of a locate set to perform a locate operation. For example, locate information related to the use of the transmitter may include, but is not limited to, information about the applied signal power, the applied signal frequency, the location of the transmitter, the connection point type (i.e., the manner in which connection is made to the target object, such as direct connection, inductive coupling, etc.), an identification of the transmitter unit (e.g., serial number), information about how the transmitter unit is grounded (if at all), and an indication of whether a sufficient electrical connection has been made to the target object (e.g., some transmitters produce a “continuity signal” indicative of the quality of the connection between the transmitter and the target object). Locate information related to the use of the locate receiver may include, but is not limited to, an identification of the locate receiver (e.g., a serial number), the mode of operation of the locate receiver (e.g., peak mode v. null mode), the frequency to which the locate receiver is tuned, the gain of the locate receiver, the frequency of a detected magnetic field, the amplitude/strength of a detected magnetic field, the electrical current of the detected signal, the location of the locate receiver, and a depth measurement taken by the locate receiver (which may be used, for example, as additional information regarding a target object). In addition, locate information relating to the locate operation itself may include, but is not limited to, information about the target object, the location of the locate site, the party requesting the locate, the party performing the locate, and whether any locate operations have previously been performed for this site.

[0112] According to some aspects of the invention, locate information relating to a locate set, and/or locate operation more generally, may be recorded, transmitted, and/or processed, for example, to enable evaluation of the performance of the locate technician, evaluation of the operation of the locate equipment, reconstruction of the actions taken by the locate technician during the locate operation, and/or to facilitate comparison of collected data to historical data. In one exemplary embodiment, a locate receiver is configured to store and/or transmit locate information relating to a locate set and/or a locate operation, and in some implementations generate an electronic record of at least some of the locate

information. Examples of locate-related information that may be logged into an electronic record may include any of the types of information described above or any suitable combinations of information of interest, and generally may include, but are not limited to:

[0113] timing information (e.g., one or more time stamps) associated with one or more events occurring during a given locate operation;

[0114] geographic information (e.g., one or more geographic coordinates) associated with one or more events of a locate operation (in some instances, the geographic information may be accompanied by timing information, such as a time stamp, for each acquisition of geographic information); and/or geographic diagnostics information (e.g., GPS diagnostics information, such as, but not limited to, the quality of a GPS signal, the number of satellites in view of the GPS receiver, etc.);

[0115] service-related information: one or more identifiers for the locate technician performing the locate operation, the locate contractor (service provider) dispatching the locate technician, and/or the party requesting the locate operation;

[0116] ticket information: information relating to one or more facilities to be located, location information (e.g., an address, geo-coordinates, and/or text description) relating to the work site and/or dig area in which the locate and marking operation is performed, ground type information (e.g., a description of the ground at which the locate is performed), excavator information, other text-based information, etc.

[0117] target object information: information about the target object (e.g., facility) to be located, such as the type of object, expected depth of object, etc.;

[0118] locate performance information: information entered, detected and/or sensed as part of performing the locate operation, such as ground type in the area of the locate operation (e.g., grass, pavement, etc., which could also or alternatively be indicated in ticket information), magnetic field strength and frequency, electric current magnitude, depth of the located object, the mode of operation of the locate receiver (e.g., peak v. null detection modes), the gain of the locate receiver, etc. With respect to locate receivers, the “gain” is typically a measure of the degree of sensitivity of a locate receiver antenna that is picking up a signal emanating from along an underground facility (alternatively, “gain” may be viewed as a degree of amplification being applied to a received signal). Gain may be expressed in terms of any scale (e.g., 0-100), as a numeric value or percentage. “Signal strength” (or “magnetic field strength”) refers to the strength of a received signal at a given gain value; signal strength similarly may be expressed in terms of any scale, as a numeric value or percentage. Generally speaking, higher signal strengths at lower gains typically indicate more reliable information from a locate receiver, but this may not necessarily be the case for all locate operations;

[0119] locate receiver information: information about the locate receiver, such as identification of the locate receiver (e.g., serial number), make and model of the locate receiver, mode of operation, battery level, etc.; and

[0120] transmitter information: information about any transmitter and transmitter signal (also referred to herein

as an applied signal) utilized for the locate operation, such as transmitter type, connection type, applied signal frequency, transmitter power, whether a continuity indication is provided for the applied signal, etc.

[0121] One or more electronic records based on the locate information described above, or any other locate-related information, may be generated, logged/stored in local memory of the locate receiver, formatted in any of a variety of manners, saved as any of a variety of file types having any of a variety of data structures, processed and/or analyzed at the locate receiver itself, and/or transmitted to another device (for example, to a computer or, in those embodiments in which multiple locate receivers are used to complete a same locate operation, to another locate receiver) for storage, processing and/or analysis.

[0122] FIGS. 4 and 5 illustrate a functional block diagram and perspective view, respectively, of one example of a data acquisition system 100, including a locate device such as a locate receiver 110 and optionally a remote computer 150, according to one embodiment of the present invention. One or both of the locate receiver 110 and the remote computer 150 of the data acquisition system 100 may be configured collect locate information relating to performance of a locate operation.

[0123] As shown in FIG. 4, in one embodiment locate receiver 110 includes control electronics 112, the components of which are powered by a power source 114. Power source 114 may be any power source that is suitable for use in a portable device, such as, but not limited to, one or more rechargeable batteries, one or more non-rechargeable batteries, a solar photovoltaic panel, a standard AC power plug feeding an AC-to-DC converter, and the like.

[0124] As also shown in FIG. 4, in one embodiment control electronics 112 of locate receiver 110 may include, but are not limited to, a processor 118, at least a portion of an actuation system 120 (another portion of which may include one or more mechanical elements), a local memory 122, a communication interface 124, a user interface 126, a timing system 128, and a location tracking system 130.

[0125] The processor 118 may be any general-purpose processor, controller, or microcontroller device. Local memory 122 may be any volatile or non-volatile data storage device, such as, but not limited to, a random access memory (RAM) device and a removable memory device (e.g., a universal serial bus (USB) flash drive, a multimedia card (MMC), a secure digital card (SD), a compact flash card (CF), etc.). As discussed further below, the local memory may store a locate data algorithm 137, which may be a set of processor-executable instructions that when executed by the processor 118 causes the processor to control various other components of the locate receiver 110 so as to generate an electronic record 135 of a locate operation, which record also may be stored in the local memory 122 and/or transmitted in essentially real-time (as it is being generated) or after completion of a locate operation to a remote device (e.g., remote computer 150). In other aspects, the local memory 122 also may store a map or image viewer application 113 (hereafter simply “map viewer application”), and one or more facilities maps or facilities map data sets 166 and/or other images 168. As discussed further below, the one or more facilities maps/data sets 166 may in some implementations include a library of facilities maps, or a database of facilities map data, for one or more different types of facilities deployed in a geographical region.

[0126] In one exemplary implementation, a Linux-based processing system for embedded handheld and/or wireless devices may be employed in the locate receiver 110 to implement various components of the control electronics 112. For example, the Fingertip4™ processing system, including a Marvell PXA270 processor and available from InHand Electronics, Inc. (www.inhandelectronics.com/products/fingertip4), may be used. In addition to the PXA270 processor (e.g., serving as the processor 118), the Fingertip4™ includes flash memory and SDRAM (e.g., serving as local memory 122), multiple serial ports, a USB port, and other I/O interfaces (e.g., to facilitate interfacing with one or more input devices and other components of the locate receiver), supports a variety of wired and wireless interfaces (WiFi, Bluetooth, GPS, Ethernet, any IEEE 802.11 interface, or any other suitable wireless interface) to facilitate implementation of the communication interface 124, and connects to a wide variety of LCD displays (to facilitate implementation of a user interface/display). In yet other exemplary implementations, the processor 118 may be realized by multiple processors that divide/share some or all of the functionality discussed herein in connection with the processor 118. For example, in one implementation, an Atom™ processor available from Intel Corporation of Santa Clara, Calif., may be used alone or in connection with one or more PIC processors to accomplish various functionality described herein.

[0127] Communication interface 124 of locate receiver 110 may be any wired and/or wireless communication interface by which information may be exchanged between locate receiver 110 and an external or remote device, such as a remote computing device that is elsewhere in the dig area (i.e., not a part of the locate receiver 110) or outside the dig area. For example, data that is provided by components of data acquisition system 100 and/or stored in local memory 122 (e.g., one or more electronic records 135, one or more facilities maps 166) may be transmitted via communication interface 124 to a remote computer, such as remote computer 150, for processing. Similarly, one or more facilities maps 166 may be received from the remote computer 150 or one or more other external sources via the communication interface 124. Examples of wired communication interfaces may include, but are not limited to, USB ports, RS232 connectors, RJ45 connectors, Ethernet, and any combination thereof. Examples of wireless communication interfaces may include, but are not limited to, an Intranet connection, Internet, Bluetooth® technology, Wi-Fi, Wi-Max, IEEE 802.11 technology (e.g., operating at a minimum bandwidth of 54 Mbps, or any other suitable bandwidth), radio frequency (RF), Infrared Data Association (IrDA) compatible protocols, Local Area Networks (LAN), Wide Area Networks (WAN), Shared Wireless Access Protocol (SWAP), any combination thereof, and other types of wireless networking protocols. The wireless interface may be capable of capturing signals that reflect a user's intent. For example, the wireless interface may include a microphone that can capture a user's intent by capturing the user's audible commands. Alternatively, the wireless interface may interact with a device that monitors a condition of the user, such as eye movement, brain activity, and/or heart rate.

[0128] User interface 126 of locate receiver 110 may be any mechanism or combination of mechanisms by which a user may operate data acquisition system 100 and by which information that is generated by data acquisition system 100 may be presented to the user. For example, user interface 126 may

include, but is not limited to, a display device (including integrated displays and external displays, such as Heads-Up Displays (HUDs)), a touch screen, one or more manual push-buttons, a microphone to provide for audible commands, one or more light-emitting diode (LED) indicators, one or more toggle switches, a keypad, an audio output (e.g., speaker, buzzer, and alarm), and any combination thereof. In one implementation, the user interface **126** includes a “menu/on” button to power up the locate receiver and provide a menu-driven graphical user interface (GUI) displayed by the display device (e.g., menu items and/or icons displayed on the display device) and navigated by the technician via a joystick or a set of four “up/down/left/right” buttons, as well as a “select/ok” button to take some action pursuant to the selection of a menu item/icon. As described below, the display may also be used in some embodiments of the invention to display information relating to one or more facilities maps and/or one or more other images germane to a locate and/or marking information, as well as information relating to a placement of marking material in a dig area, a location of an underground facility in a dig area, or any other suitable information that may be displayed based on information acquired to create an electronic record **135**.

[0129] In various embodiments, the one or more interfaces of the locate receiver **110**—including the communication interface **124** and user interface **126**—may be used as input devices to receive information to be stored in the memory **122**, to facilitate various functions of the locate receiver and/or to be logged as part of an electronic record of a locate operation. In some cases, locate information received via the interface(s) (e.g., via the communication interface **124**) may include ticket information regarding underground facilities to be detected during a locate operation. As another example, using an interface such as the user interface **126**, service-related information may be input, including an identifier for the locate receiver used by the technician, an identifier for a technician, and/or an identifier for the technician’s employer. Alternatively, some or all of the service-related information similarly may be received via the communication interface **124** (and likewise some or all of the ticket information may be received via the user interface **126**). As also noted above, facilities map information and/or other image information also may be received via the communication interface **124**.

[0130] The actuation system **120** of locate receiver **110** shown in the block diagram of FIG. **4** may include both electrical and mechanical elements according to various embodiments discussed in further detail below, and for purposes of illustration is shown in FIG. **4** as included as part of the control electronics **112**. The actuation system **120** may include a mechanical and/or electrical actuator mechanism (e.g., see the actuator **142** shown in FIG. **5**) to provide one or more signals or stimuli as an input to the actuation system **120**. Upon receiving one or more signals or stimuli (e.g., actuation/triggering by a locate technician or other user), the actuation system **120** may cause the logging of various data constituting locate information. To this end, the actuation system **120** may provide one or more output signals in the form of an actuation signal **121** to the processor **118** to indicate one or more actuations of the locate receiver, in response to which the processor **118** may acquire/collect various locate information and log data into the electronic record **135**.

[0131] Location tracking system **130** of locate receiver **110** constitutes another type of input device that provides locate information, and may include any device that can determine

its geographical location to a certain degree of accuracy. For example, location tracking system **130** may include a global positioning system (GPS) receiver or a global navigation satellite system (GNSS) receiver. A GPS receiver may provide, for example, any standard format data stream, such as a National Marine Electronics Association (NMEA) data stream, or other data formats. An error correction component **131** may be, but is not limited to, any mechanism for improving the accuracy of the geographic information provided by location tracking system **130**; for example, error correction component **131** may be an algorithm for correcting any offsets (e.g., due to local disturbances in the atmosphere) in the geo-location data of location tracking system **130**. While shown as part of a local location tracking system of the locate receiver **110**, error correction component **131** alternatively may reside at a remote computing device, such as remote computer **150**. In other embodiments, location tracking system **130** may include any device or mechanism that may determine location by any other means, such as performing triangulation by use of cellular radiotelephone towers.

[0132] In one exemplary implementation, the location tracking system **130** may include an ISM300F2-C5-V0005 GPS module available from Inventek Systems, LLC of Westford, Massachusetts (see www.inventeksys.com/html/ism300f2-c5-v0005.html). The Inventek GPS module includes two UARTs (universal asynchronous receiver/transmitter) for communication with the processor **118**, supports both the SIRF Binary and NMEA-0183 protocols (depending on firmware selection), and has an information update rate of 5 Hz. A variety of geographic location information may be requested by the processor **118** and provided by the GPS module to the processor **118** including, but not limited to, time (coordinated universal time—UTC), date, latitude, north/south indicator, longitude, east/west indicator, number and identification of satellites used in the position solution, number and identification of GPS satellites in view and their elevation, azimuth and SNR values, and dilution of precision values. Accordingly, it should be appreciated that in some implementations the location tracking system **130** may provide a wide variety of geographic information as well as timing information (e.g., one or more time stamps) to the processor **118**.

[0133] In another embodiment, location tracking system **130** may not reside locally on locate receiver **110**. Instead, location tracking system **130** may reside on any on-site computer, which serves as a location reference point, to which the location of locate receiver **110** may be correlated by any other means, such as, but not limited to, by a triangulation technique between the on-site computer and locate receiver **110**.

[0134] In some embodiments, control electronics **112** may also include one or more of an electronic compass **160**, an inclinometer **170**, and one or more accelerometers **172**. An inclinometer is an instrument for measuring angles of slope (or tilt) or inclination of an object with respect to gravity. The inclinometer **170** may be any commercially available inclinometer device. In one example, inclinometer **170** may be a digital device for sensing the inclination of the locate receiver **110** in which it is installed (i.e., senses angle of spray). An accelerometer is a device for measuring acceleration and gravity-induced reaction forces. A multi-axis accelerometer is able to detect magnitude and direction of the acceleration as a vector quantity. The acceleration specification may be in terms of g-force, which is a measurement of an object’s acceleration. The accelerometer **172** may be any commer-

cially available accelerometer device, including, for example, Part No. ADXL330 sold by Analog Devices of Wilmington, Mass. In one example, accelerometer **172** may be used for detecting the rate of movement of the locate receiver **110** in which it is installed. Electronic compass **160** may be any commercially available electronic compass, including, for example, the OS5000-S sold by OceanServer Technology, Inc. of Fall River, Mass., the SP3002D sold by SPARTON Corporation of Brooksville, Fla., the PNI-PRIME sold by PNI Sensor Corp. of Santa Rosa, Calif., the Revolution GS sold by True North LLC of Maynard, Mass., or the HMR3400 sold by Honeywell International, Inc. of Morristown, N.J.

[0135] With respect to other input devices of the locate receiver **110** that may provide locate information, the control electronics **112** may also include a timing system **128** having an internal clock (not shown), such as a crystal oscillator device, for processor **118**. Additionally, timing system **128** may include a mechanism for registering time with a certain degree of accuracy (e.g., accuracy to the minute, second, or millisecond) and may also include a mechanism for registering the calendar date. In various implementations, the timing system **128** may be capable of registering the time and date using its internal clock, or alternatively timing system **128** may receive its time and date information from the location tracking system **130** (e.g., a GPS system) or from an external timing system, such as a remote computer or network, via communication interface **124**. In yet other implementations, a dedicated timing system for providing timing information to be logged in an electronic record **135** may be optional, and timing information for logging into an electronic record may be obtained from the location tracking system **130** (e.g., GPS latitude and longitude coordinates with a corresponding time stamp). Timing information may include, but is not limited to, a period of time, timestamp information, date, and/or elapsed time.

[0136] As shown in FIGS. 4 and 5, the locate receiver **110** further includes detection electronics **131**, which provides another example of an input device that may provide location information to the processor **118**. In exemplary implementations, the detection electronics **131** in turn includes an RF antenna **127**, a detection circuit **139**, and a processing circuit **133**. Each of these components is explained in greater detail further below.

[0137] In one embodiment, information provided by one or more input devices of the locate receiver **110** (e.g., the timing system **128**, the location tracking system **130**, the detection electronics **131**, the user interface **126**, the communication interface **124**) is acquired and logged (stored in memory) upon actuation of the actuation system **120** (e.g., triggering an actuator). Some embodiments of the invention may additionally or alternatively acquire/log information from one or more input devices at one or more times during or throughout an actuation, such as when a technician is holding a mechanical or electrical actuator for some period of time and moving to detect a presence of an underground facility. In various aspects of such embodiments, locate information derived from one or more input devices may be collected at a start time of an actuation, at one or more times during an actuation, and in some cases at regular intervals during an actuation (e.g., several times per second, once per second, once every few seconds). Further, some locate information may be collected at an end of an actuation, such as time information that may indicate a duration of an actuation.

[0138] Additionally, it should be appreciated that while some locate information may be received via one or more input devices at the start of each locate operation and upon successive actuations of the locate receiver, in other cases some locate information, as well as facilities maps information and/or other image information, may be collected by or provided to the locate receiver prior to a locate operation (e.g., on power-up or reset of the locate receiver, as part of an electronic instruction or dispatch by a locate company, and/or in response to a request/query from a locate technician), and stored in local memory **122** for subsequent use by the locate receiver (e.g., display of information via the user interface display **146**, later incorporation into an electronic record, etc.). For example, prior to a given locate operation and one or more actuations of the locate receiver, one or more of ticket information, service-related information, facilities maps information, and other image information, may have already been received (e.g., via the communication interface **124** and/or user interface **126**) and stored in local memory **122**. Pursuant to a locate operation (e.g., immediately before, during and/or after a locate operation), information previously received via the interface(s) may be retrieved from the local memory (if stored there initially), and displayed and/or entered into an electronic record as appropriate, in some case together with information collected pursuant to one or more actuations of the locate receiver. In some implementations, ticket information and/or service-related information may be received via the interface(s) and stored in an entry in the electronic record **135** “directly” in response to one or more actuations of the locate receiver (e.g., without being first stored in local memory).

[0139] In sum, according to embodiments of the present invention, various locate information from one or more input devices, as well as facilities map information and/or other image information, regardless of how or when it is received, may be displayed in various manners and/or stored in memory of the locate receiver (e.g., in an electronic record of a locate operation), and in some implementations at least some of the locate information may be logged pursuant to one or more actuations of the locate receiver.

[0140] In various implementations, the optional remoter computer **150** of the data acquisition system **100** may be any external computer system with which the locate receiver **110** communicates (e.g., via the communications interface **124**). In one embodiment, the remote computer **150** may be a centralized computer, such as a central server of an underground facility locate service provider. In another embodiment, remote computer **150** may be a computer that is at or near the work site (i.e., “on-site”), e.g., a computer that is present in a locate technician’s vehicle. The remote computer may also or alternatively store one or more of the locate data algorithm **137**, the map viewer application **113**, one or more facilities maps **166** (e.g., a library/archive of facilities maps), and one or more images **168**. To this end, in some exemplary implementations, an example of a remote computer **150** may include an image server or a facilities maps server to provide facilities maps/images to the locate receiver **110**.

[0141] Whether resident and/or executed on either the locate receiver **110** or the remote computer **150**, as noted above the locate data algorithm **137** includes a set of processor-executable instructions (e.g., stored in memory, such as local memory **122** of the locate receiver) that, when executed by processor **118** of the locate receiver **110** or another processor, processes information (e.g., various locate informa-

tion) collected in response to (e.g., during) one or more actuations of the locate receiver **110**, and/or in some cases before or after a given actuation or series of actuations. Locate data algorithm **137**, when executed by the processor **118**, may cause the processor to perform collection, logging/storage (creation of electronic records), and in some instances further processing and analysis of various locate information with respect to locate receiver actuations.

[0142] While the functionality of various components of the locate receiver **110** was discussed above in connection with FIG. **4**, FIG. **5** shows some structural aspects of the locate receiver **110** according to one embodiment. For example, the locate receiver **110** may include an elongated housing **136** in which is disposed one or more elements of the actuation system **120**, one or more elements of the control electronics **112** and the power source **114**. Elongated housing **136** may be hollow or may contain certain cavities or molded compartments for installing any components therein, such as the various components of locate receiver **110** that are shown in FIG. **4**. The elongated housing **136** and other structural elements associated with the housing, as discussed below, may be formed of any rigid, semi-rigid, strong, and light-weight material, such as, but not limited to, molded plastic and aluminum.

[0143] Incorporated at a proximal end of elongated housing **136** may be a handle **138**, which provides a convenient grip by which the user (e.g., the locate technician) may carry the locate receiver **110** during use (i.e., the exemplary locate receiver depicted in FIG. **5** is intended to be a hand-held device). In one implementation, the power source **114** may be provided in the form of a removable battery pack housing one or more rechargeable batteries that are connected in series or parallel in order to provide a DC voltage to locate receiver **110**, and disposed within a compartment in the handle **138**. Such an arrangement facilitates use of conventional removable/rechargeable battery packs often employed in a variety of cordless power tools, in which the battery pack similarly is situated in a handle of the tool. It should be appreciated, however, that the power source **114** in the form of a battery pack may be disposed in any of a variety of locations within or coupled to the elongated housing **136**.

[0144] As also shown in FIG. **5**, mounted near handle **138** is user interface **126**, which may include a display **146**. The display **146** may be a touch screen display to facilitate interaction with a user/technician, and/or the user interface also may include one or more buttons, switches, joysticks, a keyboard, and the like to facilitate entry of information by a user/technician. One or more elements of the control electronics **112** (e.g., the processor **118**, memory **122**, communication interface **124**, and timing system **128**) also may be located in the proximal end of the elongated housing in the vicinity of the user interface **126** and display **146**. As with the power source **114**, it should be appreciated that one or more elements of the control electronics **112** may be disposed in any of a variety of locations within or coupled to the elongated housing **136**.

[0145] In the embodiment of FIG. **5**, the location tracking system **130** similarly may be positioned on the proximal end of the elongated housing **136** to facilitate substantially unobstructed exposure to the atmosphere; in particular, as illustrated in FIG. **5**, the location tracking system **130** may be situated on an a ground plane **133** (providing an electrical ground at least at the antenna frequency of the location tracking system, e.g., at approximately 1.5 GHz) that extends from

the proximal end of the housing **136** and is approximately parallel to the ground, surface or pavement when the locate receiver is being normally operated by a technician (so as to reduce signal modulation with subtle movements of the locate receiver). As also shown in FIG. **5**, incorporated at the distal end of elongated housing **136** is the detection electronics **131**, including RF antenna **127**

[0146] With respect to the actuation system **120**, as shown in FIG. **5**, the actuation system **120** includes an actuator **142**, which for example may be a mechanical mechanism provided at the handle **138** in the form of a trigger that is pulled by a finger or hand of an user/technician. In response to the signal/stimulus provided by the actuator **142**, as discussed above the actuation system may provide an actuation signal **121** to the processor **118** to indicate an actuation. As discussed in further detail below, pursuant to the execution by the processor **118** of the locate data algorithm **137**, the actuation signal **121** may be used to cause the logging of information that is provided by one or more components of the locate receiver **110** so as to generate an electronic record of the locate operation.

[0147] In some embodiments, a user may commence a locate operation with the locate receiver by inputting various information to the locate receiver, and/or selecting various operating options, via the user interface. As a non-limiting example, the user may select from various menu options (using the user interface and display as a menu-driven GUI), and/or manually enter via the user interface, the type of target object/facility to be located, the address of the locate operation, the ground type (e.g., grass, pavement, etc.), whether or not a separate transmitter is being used, the mode of the locate receiver (e.g., Peak v. Null), whether the locate receiver is being operated in landmark mode or not (described further below), or any other information of interest to a locate operation.

[0148] In one exemplary implementation, the user may first power on the locate receiver and log on, for example by entering a user ID. The user may then navigate through a menu on a touch screen of the user interface to select the target object to be located, for example selecting from among a list of options (e.g., including facility types such as gas, sewer, cable, and phone, etc.). Similarly, the user may then navigate through a menu to select the ground type in the area of the locate operation (e.g., selecting from a list of options including grass, pavement, dirt, etc.). The user may then similarly select or input the frequency of any applied signal provided by a transmitter, for example using a keypad of the user interface or a menu-driven GUT. It should be provided that these examples of user actions are non-limiting, and furthermore that in some embodiments one or more of the pieces of information listed may be detected automatically and not be input/selected by the user.

[0149] Once the target object/facility type and any other relevant or desired information is input and/or selected by the technician, and the applied signal from the transmitter is coupled to the target object, the locate receiver may be used in a variety of manners by the technician for a locate operation, in which the technician generally positions (e.g., sweeps) the locate receiver over an area in which they expect to detect an underground facility. More specifically, the technician positions the locate receiver such that the RF antenna **127** (which may include more than one antenna, as described further below) may receive/detect a magnetic field emitted by the target object (see underground facility **1515** in FIG. **1A**).

[0150] In some embodiments, the locate receiver **110** is capable of operating in a null mode (e.g., capable of detecting a null signal when positioned over an object (e.g., facility) emitting a magnetic field), such that RF antenna **127** may comprise a null detection antenna. Alternatively, the locate receiver **110** is capable of operating in a peak detection mode (e.g., capable of detecting a peak signal when over an object (e.g., facility) emitting a magnetic field), and the RF antenna **127** comprises two peak detection antennae, which may be positioned substantially parallel to each other but at different positions within the locate receiver (e.g., at different heights). In some embodiments, the locate receiver **110** is capable of operating in both peak detection and null detection modes, and the RF antenna **127** may comprise three antennae, e.g., one null detection antenna and two peak detection antennae. However, RF antenna **127** may comprise any other number, type, and orientation of antennae, as the locate receivers described herein are not limited in these respects.

[0151] The RF antenna **127** may be coupled to the detection circuit **139** such that the signal(s) received/detected by the RF antenna **127** may be provided to the detection circuit **139** as an output signal of the RF antenna. The output signal of the RF antenna may be any frequency detectable by the antenna, and in some embodiments may be between approximately 512 Hz and 1 MHz, although these non-limiting frequencies are provided primarily for purposes of illustration. As mentioned the output signal of the RF antenna **127**, which in some embodiments is an analog signal, may be provided to detection circuit **139**, which may perform various functions. For example, the detection circuit **139** may perform various “front-end” operations on the output signal of RF antenna **127**, such as filtering, buffering, frequency shifting or modulation, and/or pre-amplifying the output signal. Furthermore, the detection circuit **139** may perform additional functions, such as amplifying and/or digitizing the output signal provided by RF antenna **127**. It should be appreciated, however, that the types of functions described as being performed by detection circuit **139** are non-limiting examples, and that other functions may additionally or alternatively be performed.

[0152] After detection circuit **139** has operated on the signal from RF antenna **127** (e.g., by filtering, buffering, amplifying, and/or digitizing, among other possible operations), it may provide a signal to processing circuit **133**. The processing circuit **133** may process the signal(s) provided by detection circuit **139** in any suitable manner to determine any information of interest. For example, according to one embodiment, the processing circuit **133** may process the signal(s) from detection circuit **139** to determine a magnetic field strength of a magnetic field detected by RF antenna **127**. The processing circuit **133** may process the signal(s) from detection circuit **139** to determine an amplitude and/or direction of the electrical current creating the magnetic field(s) detected by RF antenna **127**. Processing circuit **133** may perform operations to calculate, for example, the depth and location of the target facility based on the electromagnetic fields detected by RF antenna **127**. Processing circuit **133** may be an analog circuit or a digital microprocessor, or any other suitable processing component for performing one or more of the operations described above, or any other operations of interest with respect to signals detected by RF antenna **127**. Also, it should be appreciated that processing circuit **133** and processor **118** may be a single processor in some embodiments, as the illustration of them as distinct in FIG. 4 is only one non-limiting example.

[0153] According to various embodiments, the manner in which locate information derived from one or more exemplary input devices is logged to local memory **122** may depend at least in part on the type of data being logged, as the operation of locate receiver **110** is not limited in this respect.

[0154] For example, data from timing system **128** and/or location tracking system **130** may be automatically logged continuously (e.g., in the form of streaming packets with flag fields, as described below, or in any other continuous form) or periodically to the local memory **122**, may be logged in response to one or more types of events (e.g., may be logged automatically when a particular event occurs), and/or may be logged at any suitable times. In particular, in one implementation, logging may occur at periodic intervals during performance of a locate operation, such as every second, every five seconds, every minute, or at any other suitable time interval. According to another embodiment, timing information and/or geographic information from timing system **128** and location tracking system **130**, respectively, may be logged in response to particular types of events, such as detecting an underground facility or detecting the absence of an underground facility. Such events may be identified by signals output by processing circuit **133** to processor **118**. As a non-limiting example, timing information and/or geographic information may be logged when a characteristic (e.g., magnetic field strength) of a signal detected by RF antenna **127** is greater than a particular threshold value, which may be indicated by a signal output from processing circuit **133** to processor **118**, and which occurrence may be indicative of the presence of an underground facility. Similarly, in some embodiments, timing information and/or geographic information may be logged when a signal detected by RF antenna **127** has a magnitude above a first threshold and the gain of the locate receiver **110** is above a second threshold. It should be appreciated that various combinations of detected signals detected by locate receiver **110** may be used to trigger logging of information (e.g., timing information and/or geographic information) to local memory. It should also be appreciated that any information available from the location tracking system **130** (e.g., any information available in various NMEA data messages, such as coordinated universal time, date, latitude, north/south indicator, longitude, east/west indicator, number and identification of satellites used in the position solution, number and identification of GPS satellites in view and their elevation, azimuth and SNR values, dilution of precision values) may be included in geographic information constituting all or a portion of logged locate information.

[0155] In some embodiments, information (e.g., timing information and/or geographic information) may be logged in response to detection of a pattern of events, or deviation from a pattern of events. For example, a pattern of magnetic field strength magnitudes (e.g., a relatively constant magnetic field strength for a given time, an increasing magnetic field strength, a decreasing magnetic field strength, etc.) may be detected by the locate receiver, which may trigger logging of timing information and/or geographic information. Deviation from a pattern, such as a historical pattern or expected pattern may also trigger logging of information. For example, a user’s historical use patterns of a locate receiver may be compared to information collected about the use of the locate receiver during a given job, and if a deviation is detected then logging of timing and/or geographic information may be triggered. The patterns or deviations from patterns may relate to patterns in magnetic field strength, magnetic field frequency, signal

gain, user operation, any other information described herein, or any combination of such information.

[0156] In some embodiments, alternatively or in addition to “automatic” logging of locate information based on some condition or event, a user of the locate receiver **110** may “manually” trigger logging of timing information, geographic information, and/or any other data associated with a locate operation or locate receiver (locate information), for example by manipulating a control (e.g., button, knob, joystick) of the user interface **126** or, as discussed above, by actuating an actuator **142** integrated or otherwise associated with the locate receiver (as shown in FIG. 5), which may be part of the actuation system **120** and which may cause a signal **121** to be sent to the processor **118** to initiate logging of locate information. For example, according to some embodiments a user may initiate the locate receiver **110** taking a depth measurement by depressing a pushbutton of the user interface **126**, or pulling/squeezing the actuator **142**, which may also trigger the logging of timing information and/or geographic information from timing system **128** and location tracking system **130**. The depth measurement data, time data, and/or location data may then be logged in an electronic record **135** in local memory **122**.

[0157] It should be appreciated that while the foregoing discussion focuses on logging locate information to local memory **122**, the locate information may also, or alternatively, be transmitted to remote computer **150** via communication interface **124**. As with logging locate information to local memory **122**, the transmission of locate information to remote computer **150** may be performed continuously, periodically in response to one or more types of events, in response to user input or actuation of an actuator, or in any other suitable manner.

[0158] In yet other embodiments, the locate receiver **110** may be configured (e.g., via particular instructions executing on the processor **118**) to operate in multiple different modes to collect various information relating not only to a locate operation (locate information), but additionally or alternatively various information relating to the work site/dig areas in which the locate operation is performed. For example, in one implementation, the locate receiver may be configured to operate in a first “locate mode” which essentially follows various aspects of the operation of the locate receiver **110** described herein, and also may be configured to operate in a second “landmark identification mode.” When switched into the landmark mode, the locate receiver may stop detecting a magnetic field, e.g., the RF antenna of the locate receiver may be temporarily disabled in some embodiments. In other embodiments, the locate receiver may continue to operate and the landmark mode may represent additional functionality added to the locate receiver functionality.

II. FACILITIES MAPS

[0159] As noted above and discussed in further detail below, various embodiments of the present invention relate to accessing and displaying facilities map information. A facilities map is any physical, electronic, or other representation of the geographic location, type, number, and/or other attributes of a facility or facilities. Facilities maps may be supplied by various facility owners and may indicate the geographic location of the facility lines (e.g., pipes, cables, and the like) owned and/or operated by the facility owner. For example, facilities maps may be supplied by the owner of the gas

facilities, power facilities, telecommunications facilities, water and sewer facilities, and so on.

[0160] As indicated above, facilities maps may be provided in any of a variety of different formats. As facilities maps often are provided by facility owners of a given type of facility, typically a set of facilities maps includes a group of maps covering a particular geographic region and directed to showing a particular type of facility disposed/deployed throughout the geographic region. One facilities map of such a set of maps is sometimes referred to in the relevant arts as a “plat.”

[0161] Perhaps the simplest form of facilities maps is a set of paper maps that cover a particular geographic region. In addition, some facilities maps may be provided in electronic form. An electronic facilities map may in some instances simply be an electronic conversion (i.e., a scan) of a paper facilities map that includes no other information (e.g., electronic information) describing the content of the map, other than what is printed on the paper maps.

[0162] Alternatively, however, more sophisticated facilities maps also are available which include a variety of electronic information, including geographic information and other detailed information, regarding the contents of various features included in the maps. In particular, facilities maps may be formatted as geographic information system (GIS) map data, in which map features (e.g., facility lines and other features) are represented as shapes and/or lines, and the metadata that describes the geographic locations and types of map features is associated with the map features. In some examples, a GIS map data may indicate a facility line using a straight line (or series of straight lines), and may include some symbol or other annotation (e.g., a diamond shape) at each endpoint of the line to indicate where the line begins and terminates. From the foregoing, it should be appreciated that in some instances in which the geo-locations of two termination or end-points of a given facility line may be provided by the map, the geo-location of any point on the facility line may be determined from these two end-points.

[0163] Examples of a wide variety of environmental landmarks and other features that may be represented in GIS facilities map data include, but are not limited to: landmarks relating to facilities such as pedestal boxes, utility poles, fire hydrants, manhole covers and the like; one or more architectural elements (e.g., buildings); and/or one or more traffic infrastructure elements (e.g., streets, intersections, curbs, ramps, bridges, tunnels, etc.). GIS facilities map data may also include various shapes or symbols indicating different environmental landmarks relating to facilities, architectural elements, and/or traffic infrastructure elements.

[0164] Examples of information provided by metadata include, but are not limited to, information about the geo-location of various points along a given line, the termination points of a given line (e.g., the diamond shapes indicating the start and end of the line), the type of facility line (e.g., facility type and whether the line is a service line or main), geo-location of various shapes and/or symbols for other features represented in the map (environmental landmarks relating to facilities, architectural elements, and/or traffic infrastructure elements), and type information relating to shapes and/or symbols for such other features.

[0165] The GIS map data and metadata may be stored in any of a variety of ways. For example, in some embodiments, the GIS map data and metadata may be organized into files, where each file includes the map data and metadata for a

particular geographic region. In other embodiments, the GIS map data and metadata may be stored in database and may be indexed in the database by the geographical region to which the map data and metadata corresponds.

[0166] Facilities maps may include additional information that may be useful to facilitate a locate and/or marking operation. For example, various information that may be included in a legend of the facilities map, or otherwise associated with the facilities map (e.g., included in the metadata or otherwise represented on the map), may include, but is not limited to, a date of the facilities map (e.g., when the map was first generated/created, and/or additional dates corresponding to updates/revisions), a number of revisions to the facilities map (e.g., revision number, which may in some instances be associated with a date), one or more identifiers for a source, creator, owner and/or custodian of the facilities map (e.g., the owner of the facility type represented in the map), various text information (e.g., annotations to update one or more aspects or elements of the map), and any other legend information that may be included or represented in the map.

[0167] For facilities maps in electronic form, a variety of digital formats of facilities maps may be used including, but not limited to, a vector image format that is the typical output format of computer-aided design (CAD) tools. In one example, some facilities maps may be in a DWG (“drawing”) format, which is a format that used for storing two and three dimensional design data and metadata, and is a native used by several CAD packages including AutoCAD, Intellicad, and PowerCAD. However, those skilled in the art will recognize that facilities maps may be in any of several vector and/or raster image formats, such as, but not limited to, DWG, DWF, DGN, PDF, TIFF, MFI, PMF, and JPG.

[0168] As noted above, in some instances in which facilities maps are in a vector image format, a certain line on the facilities map may be represented by a starting point geo-location, an ending point geo-location, and metadata about the line (e.g., type of line, depth of line, width of line, distance of line from a reference point (i.e., tie-down), overhead, underground, line specifications, etc.). According to one embodiment of the present invention as discussed in greater detail below, to facilitate display of facilities map information relating to multiple different types of facilities, each vector image may be assembled in layers, in which respective layers correspond, for example, to different types of facilities (e.g., gas, water, electric, telecommunications, etc.). In one aspect of such an embodiment, each layer is, for example, a set of vector images that are grouped together in order to render the representation of the certain type of facility.

[0169] FIG. 6 shows an example of a visual representation of a portion of an electronic facilities map **600**. In this example, facilities map **600** is a telecommunications facilities map that is supplied by a telecommunications company. Facilities map **600** shows telecommunications facilities in relation to certain landmarks, such as streets and roads, using lines and shapes. As discussed above, the electronic facilities map may include metadata indicating what various lines, symbols and/or shapes represent, and indicating the geo-location of these lines, symbols and/or shapes. With respect to exemplary environmental landmarks and other features, facilities map **600** may include both visual information (graphics and text) and metadata relating to utility poles **602**, manhole **604**, streets **606**, and any of a variety of other land-

marks and features that may fall within the geographic area covered by the facilities map **600**.

III. OTHER TYPES OF IMAGE INFORMATION

[0170] As also noted above and discussed in further detail below, various embodiments of the present invention relate to accessing and displaying not only facilities map information but other types of image information as well and, as with facilities map information, different images can be selected for viewing on a locate device (e.g., the locate receiver **110**) at different times, according to various criteria. In some exemplary implementations, an “input image” may be stored in local memory **122** of the locate receiver and/or retrieved from the optional remote computer **150** (e.g., via the communication interface **124**) and then stored in local memory, accessed, and various information may be derived therefrom for display (e.g., all or a portion of the input image, metadata associated with the input image, etc.).

[0171] For purposes of the present application, an input image is any image represented by source data that is electronically processed (e.g., the source data is in a computer-readable format) to display the image on a display device. An input image may include any of a variety of paper/tangible image sources that are scanned (e.g., via an electronic scanner) or otherwise converted so as to create source data (e.g., in various formats such as XML, PDF, JPG, BMP, etc.) that can be processed to display the input image, including scans of paper facilities maps. An input image also may include an image that originates as source data or an electronic file without necessarily having a corresponding paper/tangible copy of the image (e.g., an image of a “real-world” scene acquired by a digital still frame or video camera or other image acquisition device, in which the source data, at least in part, represents pixel information from the image acquisition device).

[0172] In some exemplary implementations, input images may be created, provided, and/or processed by a geographic information system (GIS) that captures, stores, analyzes, manages and presents data referring to (or linked to) location, such that the source data representing the input image includes pixel information from an image acquisition device (corresponding to an acquired “real world” scene or representation thereof), and/or spatial/geographic information (“geo-encoded information”).

[0173] In view of the foregoing, various examples of input images and source data representing input images, to which the inventive concepts disclosed herein may be applied, include but are not limited to:

[0174] Manual “free-hand” paper sketches of the geographic area (which may include one or more buildings, natural or man-made landmarks, property boundaries, streets/intersections, public works or facilities such as street lighting, signage, fire hydrants, mail boxes, parking meters, etc.);

[0175] Various maps indicating surface features and/or extents of geographical areas, such as street/road maps, topographical maps, military maps, parcel maps, tax maps, town and county planning maps, call-center and/or facility polygon maps, virtual maps, etc. (such maps may or may not include geo-encoded information);

[0176] Architectural, construction and/or engineering drawings and virtual renditions of a space/geographic area (including “as built” or post-construction drawings);

- [0177] Land surveys, i.e., plots produced at ground level using references to known points such as the center line of a street to plot the metes and bounds and related location data regarding a building, parcel, utility, roadway, or other object or installation;
- [0178] A grid (a pattern of horizontal and vertical lines used as a reference) to provide representational geographic information (which may be used “as is” for an input image or as an overlay for an acquired “real world” scene, drawing, map, etc.);
- [0179] “Bare” data representing geo-encoded information (geographical data points) and not necessarily derived from an acquired/captured real-world scene (e.g., not pixel information from a digital camera or other digital image acquisition device). Such “bare” data may be nonetheless used to construct a displayed input image, and may be in any of a variety of computer-readable formats, including XML); and
- [0180] Photographic renderings/images, including street level, topographical, satellite, and aerial photographic renderings/images, any of which may be updated periodically to capture changes in a given geographic area over time (e.g., seasonal changes such as foliage density, which may variably impact the ability to see some aspects of the image).
- [0181] It should also be appreciated that source data representing an input image may be compiled from multiple data/information sources; for example, any two or more of the examples provided above for input images and source data representing input images, or any two or more other data sources, can provide information that can be combined or integrated to form source data that is electronically processed to display an image on a display device.
- [0182] Various examples of input images as discussed above are provided in FIGS. 7-12. For example, FIG. 7 shows a sketch 1000, representing an exemplary input image; FIG. 8 shows a map 1100, representing an exemplary input image; FIG. 9 shows a construction/engineering drawing 1300, representing an exemplary input image; FIG. 10 shows a land survey map 1400, representing an exemplary input image; FIG. 11 shows a grid 1500, overlaid on the construction/engineering drawing 1300 of FIG. 9, representing an exemplary input image; and FIG. 12 shows a street level image 1600, representing an exemplary input image.

IV. DISPLAYING FACILITIES MAP INFORMATION AND/OR OTHER IMAGE INFORMATION ON A LOCATE DEVICE

- [0183] In some embodiments, locate receiver 110 may display various information relating to one or more facilities maps or one or more input images on display 146. For example, processor(s) 118 may access facilities map data (e.g., from a file or a database) stored in local memory 122 or may retrieve facilities map data stored on remote computer 150 and may display on display 146 facilities maps based on the facilities map data.
- [0184] In some embodiments, processor 118 may execute a map viewer application 113 for displaying facilities maps and/or input images. The map viewer application 113 may be a custom application or any conventional viewer application that is capable of reading in electronic facilities maps data or other input images, and rendering all or a portion of the electronic facilities maps data/input images to an image that can be viewed on display 146. Examples of conventional map

viewer applications suitable for purposes of some embodiments of the present invention include, but are not limited to, the Bentley® viewer application from Bentley Systems, Inc. (Exton, Pa.) and the ArcGIS viewer application from Environmental Systems Research Institute (Redlands, Calif.). While the discussion below initially focuses on the display of facilities map information for purposes of illustrating some of the inventive concepts disclosed herein, it should be appreciated that the various concepts discussed below apply generally to the display of other types of image information as well.

[0185] Processor 118 may select a map to be displayed on display 146 in any of variety of ways. In some embodiments, a technician using the locate receiver may manually select a map to be displayed. For example, the technician may access a list of facilities maps available in local memory 122 and/or stored on remote computer using user interface 126 (e.g., via a menu-driven graphics user interface on the user interface 126) and may select a desired map from the list. In response, processor 118 may access the corresponding map data and render an image of the map or a portion of the map on display 146 (e.g., using the map viewer application 113). The technician may then also adjust the particular portion of the map that is displayed on display 146 by using user interface 146 to pan or scroll to the desired portion of the map, and may additionally select the desired zoom level at which the portion of the map is displayed.

[0186] In some embodiments, processor 118, in addition to or instead of providing the capability for a user/technician to manually select facilities map information to be displayed on display 146, may also automatically select a facilities map and display all or a portion of the selected facilities map on display 146. A variety of techniques may be used to automatically select a facilities map to be displayed on display 146, as well as a default pan and/or zoom for the selected map, and the invention is not limited to any particular technique.

[0187] In some embodiments, a facilities map may be automatically selected for display based, at least in part, on the type of facility being detected by the locate receiver and/or the current location of the locate receiver (e.g., obtained from the location tracking system).

[0188] For example, in some embodiments, processor 118 may determine the type of facility being detected by the locate receiver (e.g., using ticket information provided via the communications interface 124, or information provided by a technician via the user interface 126) and select a facilities map based on that facility type. Additionally, in some implementations, the locate receiver may be in communication with a marking device that provides marking information to the locate receiver, including information regarding the type of facility being marked. Examples of communicatively coupled locate receivers and marking devices are discussed in U.S. non-provisional application Ser. No. 12/571,397, filed Sep. 30, 2009 under attorney docket no. D0687.70055US00, entitled “Systems and Methods for Generating Electronic Records of Locate and Marking Operations,” which application is incorporated herein by reference. As discussed in this application, a marking material detection mechanism of a marking device may determine the type of facility being marked by determining the color of the marking material loaded into and/or being dispensed by the marking device. Because each marking material color corresponds to a particular type of facility, the color of the marking material may

be used to select a facilities map. Table 1 shows an example of the correspondence of marking material color to the type of facility to be marked.

TABLE 1

<u>Correspondence of color to facility type</u>	
Marking material color	Facility Type
Red	Electric power lines, cables or conduits, and lighting cables
Yellow	Gas, oil, steam, petroleum, or other hazardous liquid or gaseous materials
Orange	Communications, cable TV, alarm or signal lines, cables, or conduits
Blue	Water, irrigation, and slurry lines
Green	Sewers, storm sewer facilities, or other drain lines
White	Proposed excavation
Pink	Temporary survey markings
Purple	Reclaimed water, irrigation, and slurry lines
Black	Mark-out for errant lines

[0189] Thus, for example, if processor 118 receives a communication from a marking device, in which the marking device has determined from marking material detection mechanism that the color of the marking material loaded into and/or being dispensed by the marking device is red, then electric power lines may be determined as the type of facility being marked. As another example, if processor 118 determines from a communication from a marking device that the color of the marking material loaded into and/or being dispensed by the marking device is yellow, then gas lines may be determined as the type of facility being marked.

[0190] In other implementations, the processor 118 may prompt, via user interface 126, the technician using the locate receiver to manually input the type of facility being marked, and may accept the technician's input as the type of facility being marked. In yet another embodiment, facility type information may be derived from the ticket information, which typically includes one or more member codes representing facility owners of different types of facilities. Available ticket information may be parsed to determine relevant facility types based on one or more member codes present in the ticket information (e.g., the locate receiver, via the communications interface, may receive information from another source in which tickets have been parsed to provide facility type information; alternatively, tickets themselves may be received via the communication interface, and the processor 118 may be configured to parse tickets to obtain facility type information). Accordingly, in some implementations, one or more appropriate facilities maps may be selected, before the locate operation, based on facility type information derived from the ticket information.

[0191] In some embodiments, once the type of facility being located has been determined, processor 118 may select a facilities map, or facilities map data, to render a display on display 146 by determining the current geo-location of the locate receiver and selecting a facilities map or facilities map data corresponding to the facility type being located based on the current location of the locate receiver. Processor 118 may determine the current geo-location of the locate receiver from location tracking system 130 and may select a facilities map or facilities map data for the type of facility being detected that includes the current geo-location. For example, if the current location of the locate receiver is 2650.9348,N,08003.

5057,W, and the type of facility is electric power lines, processor 118 may access facilities map data that covers an area including 2650.9348,N,08003.5057,W and includes data indicating the location of electric power lines in this area, and may render a map image on display 146 showing the area and location of the electric power lines in that area.

[0192] Other techniques for automatically selecting a facilities map or facilities map data to render a displayed image may be used. For example, in some embodiments, processor 118 may select a facilities map or facilities map data to be displayed using information from the ticket for a particular locate operation. For example, an address from the ticket may be used to select facilities map data that covers the geographic area in which the address is located. In some embodiments, one or more member codes from the ticket may be used to determine a facility type that is to be marked and automatically select the appropriate facilities map data for that facility type. For example, if a ticket includes a member code for the gas company, processor 118 may automatically select gas facilities map data. In some situations, a ticket may include multiple member codes corresponding to different utility types. In such situations, standard operating procedure may be used to determine which facilities map to automatically select first. For example, a ticket may include member codes for the gas company and the electric company. Standard operating procedure may be specify that gas is to be marked before electric and, as such, processor 118 may automatically select the gas facilities map data to be displayed first and, once the gas locate and marking operation is complete, may automatically select the electric facilities map to be displayed next.

[0193] In some embodiments, information about the entity that requested that the locate operation be performed may be used in automatically selecting facilities map data. For example, if the electric company requested that the locate operation be performed, processor 118 may automatically select the electric facilities map data to be visually rendered and displayed.

[0194] In addition, in some embodiments, facilities map data may be selected based on a virtual white line (VWL) image that includes markings imposed on an image that delimit an area in which excavation is planned. Thus, for example, processor 118 may select facilities map data that includes the area indicated by the markings.

[0195] In some embodiments, once facilities map data has been automatically selected, a portion of the facilities map or facilities map data to render an image on display 146 may be identified. That is, the facilities map data that has been automatically selected may cover an area significantly larger than the work site/dig area at which a locate and/or marking operation is being conducted, and thus only a portion of the selected map data needs to be displayed on display 146. Accordingly, in some embodiments, the map viewer application 113 executing on processor 118 may display only a portion of the facilities map data on display 146. The portion of the facilities map to be displayed may be selected in a variety of ways. For example, in some embodiments, a technician may have the ability to manually select the portion of a facilities map that is desired to be displayed on display 146. As an example, once a particular facilities map has been automatically selected, the facilities map may be displayed on display 146 at a default zoom level, centered at the current geo-location of the locate receiver. If the technician desires to a view a different portion of the map or adjust the zoom level, the technician may pan or

scroll to a different part of the map and adjust the zoom level using the controls of user interface **126**.

[0196] In some embodiments, in addition to or instead of providing a technician with the capability to manually select a portion of a facilities map data to be displayed, processor **118** may automatically select a portion of the facilities map data to be displayed. For example, in some embodiments, processor **118** may select a portion of the selected facilities map data to be displayed based on one or more aspects of the ticket information pursuant to which the locate and/or marking operation is being performed. In particular, as noted above, the ticket information generally includes some description of the work site/dig area (in which excavation, digging or otherwise disturbing the ground is anticipated). While conventionally such information about the work site/dig area may be included as text comments in the ticket information, in some instances the ticket information may include a digital image (e.g., an aerial image) of a geographic area surrounding/proximate to the work site, on which are placed (e.g., via an electronic drawing tool) one or more dig area indicators to indicate or delimit a dig area. These marked-up digital images may be saved together with metadata pertaining to various information in the images.

[0197] An example of a drawing application that may be used to create such marked-up images including dig area indicators is described in U.S. patent application Ser. No. 12/366,853 filed Feb. 6, 2009, entitled "Virtual white lines for delimiting planned excavation sites;" U.S. patent application Ser. No. 12/475,905 filed Jun. 1, 2009, entitled "Virtual white lines for delimiting planned excavation sites of staged excavation projects;" U.S. patent application Ser. No. 12/422,364 filed Apr. 13, 2009, entitled "Virtual white lines (VWL) application for indicating a planned excavation or locate path." Each of these patent applications is hereby incorporated by reference herein in its entirety.

[0198] In one example, the dig area indicators in a marked-up image may include two-dimensional (2D) drawing shapes, shades, points, symbols, coordinates, data sets, or other indicators to indicate on a digital image the dig area in which excavation is to occur. To generate the electronic image having dig area indicators, an image (e.g., an aerial image) of the work site may be sent to an excavator via a network, the excavator may use a computing device executing the drawing application to create a marked-up image by marking up the image to include one or more dig area indicators precisely delimiting one or more dig areas within the work site and, in response, the marked-up image may be received from the excavator via the network.

[0199] As noted above, a marked-up image may include metadata corresponding to any markings or content in the image; in particular, geographic information including geographic coordinates (e.g., latitude and longitude values) for any dig area indicators on the marked-up image may accompany or be included in an image file as metadata, and these geographic coordinates may be employed in a variety of manners to select a portion of the facilities map data to be displayed on display **146**.

[0200] For example, in some embodiments, the portion of the facilities map data to be displayed may be selected to include all or a portion of the dig area as indicated on the marked-up image. In particular, in one exemplary implementation, geographic coordinates associated with a single dig area indicator may be used to select facilities map contents that relates only to a geographic area including the geo-

graphic coordinates for the dig area indicator, or contents that falls within a predetermined radius of the geographic coordinates for the dig area indicator or a polygon-shaped buffer zone around the geographic coordinates for the dig area indicator. In yet another example, geographic coordinates associated with multiple dig area indicators that delimit a specific dig area may be used to select only contents of the facilities map that corresponds to the delimited dig area. In yet another embodiment, the contents of the facilities map that corresponds to the delimited dig area may be displayed with a "buffer frame" around the delimited dig area (e.g., to provide some margins for the viewed subject matter). Accordingly, it should be appreciated that in some embodiments, the dig area indicator coordinates may identify a plurality of points along a perimeter of the delimited dig area, and these coordinates may be used to select specific geographic information from the facilities maps (e.g., filter out geographic information outside of the delimited dig area). In other embodiments, the dig area indicator coordinates may identify a single point, in which case the coordinates may be used to select particular information based at least in part on the coordinates for the single point.

[0201] In some embodiments, the map viewer application **113** executing on processor **118** may automatically select an orientation of the map or portion of the map that is displayed on display **146** based on the direction in which a technician of the locate receiver is moving. In some conventional techniques for displaying map information, a displayed map generally is oriented so that north is at the top of the display and south is at the bottom of the display. However, the inventors have appreciated that when displaying a facilities map or portion thereof on a locate receiver during a locate and/or marking operation, orienting the map such that the direction in which the technician is moving is at the top of the map may aid the technician in identifying the location of underground facilities relative to his or her current position. Thus, for example, if the technician is walking north, then the map viewer application may display the selected portion of the map such that north is at the top of the screen. If the technician turns left and is walking west, then the map viewer application may re-orient the selected portion of the map such that west is at the top of the screen. In this manner, the map viewer application **113** executing on processor **118** may update the portion and/or the orientation of the facilities map that is being displayed **146** in essentially real-time (e.g., update one or more of pan, zoom, and orientation as the technician moves from one place to another during the operation).

[0202] The map viewer application **113** may determine the direction in which a technician is walking using any of a variety of techniques. For example, in some embodiments, processor **118** may monitor the current geo-location of the locate receiver as indicated by location tracking system **130**, determine the direction in which the locate receiver is moving based on changes in the geo-location, and provide this direction to the map viewer application. For example, in some embodiments processor **118** may determine the direction in which the locate receiver is moving by obtaining the current heading from the electronic compass.

[0203] In some embodiments, as noted above, the locate receiver **110** may include other devices that may be used to determine the direction in which the locate receiver is moving, such as a compass, an accelerometer, and/or an inclinometer. Thus, in some embodiments, processor **118** may use these devices instead of or in addition to location tracking

system **130** to determine the direction in which the locate receiver is moving. For example, in some embodiments, the compass may be used to determine a heading in which the locate receiver is moving. In other embodiments, the accelerometer and/or inclinometer may be used to determine the direction in which the locate receiver is moving.

[0204] To demonstrate the concept of automatically orienting and positioning a portion of a facilities map based on technician/device movement and heading, FIG. **13** illustrates an example of a video frame sequence **400** that may be displayed on display **146** of locate receiver **110** as a technician moves the locate receiver to different geo-locations during a locate and/or marking operation. To illustrate video frame sequence **400**, FIG. **13** shows an example facilities map **410**, which is the facilities map to be displayed on display **146**. Facilities map **410** shows, for example, an intersection **412** of Roosevelt Avenue, which runs east and west, and Walnut Street, which runs north and south. Installed along Roosevelt Avenue and/or Walnut Street is a first underground facility **414** and a second underground facility **416**. By way of example, video frame sequence **400** shows a frame sequence that is presented on display **146** (e.g., by the map viewer application **113**) to the technician while in the process of locating and/or marking the first underground facility **414**. Each frame of video frame sequence **400** represents a segment of facilities map **410** that is being displayed.

[0205] Referring to FIG. **13**, as the locate technician moves in a northerly direction along Walnut Street, frame **1** of video frame sequence **400** that is displayed on display **146** shows underground facility **414** at the south end of Walnut Street with respect to facilities map **410**. Additionally, frame **1** is oriented on display **146** with a north heading.

[0206] As the locate technician continues to move in a northerly direction along Walnut Street, frame **2** of video frame sequence **400** that is displayed on display **146** shows underground facility **414** while approaching intersection **412** of facilities map **410**. Additionally, frame **2** is still oriented on display **146** with a north heading.

[0207] As the locate technician continues to move in a northerly direction through intersection **412**, frame **3** of video frame sequence **400** that is displayed on display **146** shows underground facility **414** at intersection **412**. Additionally, frame **3** is still oriented on display **114** with a north heading.

[0208] As the locate technician changes direction and moves in a westerly direction along Roosevelt Avenue, frame **4** of video frame sequence **400** that is displayed on display **146** shows underground facility **414** while exiting intersection **412** along Roosevelt Avenue. Additionally, frame **4** the orientation of facilities map **410** on display **146** has been updated from a north heading to a west heading.

[0209] As the locate technician continues to move in a westerly direction along Roosevelt Avenue, frame **5** of video frame sequence **400** that is displayed on display **146** shows underground facility **414** at the west end of Roosevelt Avenue with respect to facilities map **410**. Additionally, frame **5** is still oriented on display **146** with a west heading.

[0210] The inventors have appreciated that, in some situations where the locate technician is moving in a particular direction, the locate technician may reach a location that is at the end of a the portion of the map that is currently being displayed, such that if the technician were to continue to move along a vector that includes a component in that direction, his or her location will no longer be a location on the portion of

the map that is currently being displayed, but rather may be a location that is in a different map portion.

[0211] Thus, in some embodiments, when a location technician moves from a location that is on the map portion currently being displayed to a location that is not on the map portion that is currently being displayed, processor **118** may determine that the technician has moved off the map portion that is currently being displayed. Processor **118** may then identify and select additional map data (e.g., stored in the local memory **122** of the locate receiver, or retrieved from a library/archive stored on remote computer **150**) that includes the location to which the technician has moved and cause the map viewer application **113** to display this other map, in a manner similar to that discussed above in connection with appropriate selection of maps/images for display.

[0212] In addition, in some embodiments, it may be desired to display a map such that the current location of the technician is roughly centered on the display. In this way, as the technician moves, the portion of the map that is displayed is adjusted so that the geographic location of technician on the map is displayed roughly in the center of the display. In such embodiments, the technician may be at a geographic location that is near or at the end of the currently displayed map portion. Thus, if the current location of the technician were to be displayed at roughly the center of the display, then a portion of the display may be left blank because the map data that belongs in that portion of the display is not in the map currently being displayed. Thus, in some embodiments, to address this issue, processor **118** may determine when the technician is at a location that warrants additional map data to be displayed on the display at the same time, determine which additional map data includes the desired data, stitch together a map image using the additional map data, and cause this "stitched together" image to be displayed on the display.

[0213] While the concepts described immediately above (e.g., updating pan, zoom and/or orientation of displayed content based on technician/device movement and heading) were discussed for purposes of illustration using facilities map information, it should be appreciated that the foregoing discussion applies similarly to other types of image information (e.g., from one or more of the input images discussed above in Section III).

[0214] FIG. **14** illustrates a flow diagram of a process **500** for selecting and viewing facilities map information or other image information on a locate device, such as locate receiver **110**, according to one embodiment of the present invention. Process **500** begins at act **512** where the type of facility to be detected is established manually or automatically using, for example, any of the techniques discussed above. The process then continues to act **514**, where the location tracking system of the locate receiver is queried for the current geo-location information. The geo-location data from location tracking system **158** may be provided, in a variety of different formats, including for example, in degrees, minutes, and seconds (i.e., DDD° MM' SS.S"), degrees and decimal minutes (DDD° MM.MMM'), decimal degrees (DDD.DDDDD°), and/or any combination thereof.

[0215] The process next continue to act **516**, where facilities map data that matches the determined facility type determined in act **512** and the geo-location determined in act **514** is identified. The process then continues to act **518**, where the map viewer application reads in the identified facilities map data, preparing to present an image of this facilities map on the display of the locate receiver. The processor then contin-

ues to act 520, where the current heading (i.e., the direction in which the locate receiver is moving) is determined from, for example, the location tracking system, compass, inclinometer, and/or accelerometer. Once the current heading is determined, the process continues to act 522, where a map or map image segment is oriented according to the determined heading and centered according to the current geo-location of the locate receiver, and the facilities map image is presented on the display of the locate receiver.

[0216] In some embodiments, the locate receiver may alert the technician when he or she is at a location of a facility line, as indicated by the facilities map data. Thus, in some embodiments, the process may continue to act 524, where an alert to the locate technician may be generated based on comparing current geo-location of the locate receiver to the geo-location of the facilities of the displayed facilities map. In particular, in one exemplary implementation, the geo-location of the facilities of the displayed facilities map constitutes “reference information,” to which “field information” in the form of the geo-location of the locate receiver may be compared. Various methods and apparatus for comparing field information in the context of locate and marking operations to reference information derived from facilities maps is discussed in U.S. application Ser. No. 12/571,356, filed Sep. 30, 2009, and entitled, “Method And Apparatus For Analyzing Locate And Marking Operations With Respect To Facilities Maps,” which is incorporated herein by reference in its entirety.

[0217] In one example, processor 118 may compare the geo-location data of location tracking system 130 to the geo-location information in the displayed facilities map. When the two geo-locations substantially match (within a certain acceptable tolerance), an audible indicator, such as a buzzer or alarm may be activated, a tactile indicator such as a device that vibrates the handle of the locate receiver, and/or a visual indicator, such as an LED of user interface 126, may be activated in order to alert the locate technician that he or she is at or near the location of the target facility to be detected.

[0218] In other embodiments, if the location of the locate receiver differs from the location at which the facilities map (s) indicate the facility line to be detected is located by at least a threshold distance (e.g. six feet or any other suitable threshold distance), processor 118 may cause an alert (e.g., an audible indicator, a tactile indicator, and/or a visual indicator) to the technician to be activated. In addition, any discrepancies between the locations at which location information is logged and the locations of the facility lines to be detected as indicated on the facilities map may be logged and later evaluated to determine whether the discrepancy is a result of facilities map inaccuracy or locate technician error.

[0219] As shown in FIG. 14, the acts of process 500 may repeat any number of times and at any programmed frequency (e.g., every 100 milliseconds) until the locate operation is complete. With each iteration of the acts of process 500, the map viewer application updates (or refreshes) the display with the current facilities map information in order to reflect any changing geo-location and/or heading of the locate receiver as the technician performs the locate operation.

IV. OVERLAY OF LOCATE INFORMATION ON DISPLAYED FACILITIES MAP INFORMATION OR OTHER IMAGE INFORMATION

[0220] The inventors have appreciated that, as a technician using a locate receiver detects one or more underground facilities during a locate operation, it may be useful to overlay,

on displayed facilities map information or other displayed image information, electronic marks (“electronic detection marks”) that indicate where the facility/facilities were detected. This provides the locate technician with a visual representation of where facilities were detected by the locate receiver relative to the location of facility lines shown on the facilities map. In addition, in some situations, it may be desirable to overlay one or more indicators, such as a “you are here” icon or a pointer icon on the displayed facilities map or other image information, to provide the technician with a visual representation of his or her current location on the displayed portion of the map.

[0221] FIG. 15 is an example of a process that may be used to overlay data, such as electronic detection marks indicative of geo-locations at which underground facilities were detected via a locate receiver, a present location indicator or a “you are here” icon indicative of the current location of the locate receiver, or any other type of data, on displayed facilities map information or other image information, according to one embodiment of the present invention.

[0222] The process of FIG. 15 begins at act 901, where the geo-location data of the locate information to be overlaid (e.g., geo-location data corresponding to a detected facility, or current location mark) is determined/collected. For example, if the information to be overlaid is a current location mark or “you are here” icon indicative of the current location of the locate receiver, the current location of the location receiver may be determined from location tracking system 130. If the information to be overlaid is an electronic detection mark indicative of a geo-location at which a facility is detected, the geo-location data may be collected from the location tracking system 130 (e.g., in response to actuation of the locate receiver, or automatic logging of location information) and/or determined, for example, from the electronic record 135 generated and stored by the locate receiver. That is, as discussed above, in some embodiments, each time the locate receiver 110 is actuated, or characteristics of the magnetic field meet or exceed certain thresholds, the location tracking system may be polled to provide one or more geo-location data points that may be overlaid on displayed facilities map information or other image information as an electronic detection mark, essentially in real-time as the data is collected; additionally or alternatively, the geo-location data may be logged as data event entries in the electronic record 135 and the electronic record 135 may be accessed thereafter to obtain geo-location data for overlaying on displayed facilities map or other image information one or more electronic detection marks.

[0223] Table 2, shown below, lists an example of the contents of an electronic record of locate information that may be generated and stored and/or transmitted relating to operation of a locate receiver, according to one non-limiting embodiment. The electronic record shown in Table 2 includes a record number (record #1001), an identification of the service provider, an identification of the user (i.e., the locate technician operating the locate receiver), and an identification of the locate receiver. The mode of operation of the locate receiver (e.g., peak) may also be included. Timing information (timestamp data) from a timing system of the locate receiver and geographic information from a location tracking system of the locate receiver may also be included. The signal strength and signal frequency entries of the electronic record indicate characteristics of a signal (e.g., a magnetic field) detected by the locate receiver, for example emitted from an underground

facility. The signal strength is listed in the example of Table 2 as a percentage of the maximum detectable by the locate receiver, although it should be appreciated that other units of measurement may alternatively be used. The gain entry indicates the gain setting of the locate receiver. The electronic record also includes an entry for the depth of the facility targeted, as may be determined by taking a depth measurement using a locate receiver (e.g., by calculating a difference in magnetic field strength detected by two different antennae at two different locations within a locate receiver), and for the facility type (e.g., gas, electric, etc.) and ground type in the area of the locate operation. The electronic record of Table 2 also includes the address of the locate operation and the party requesting the locate operation. Lastly, Table 2 includes information about the remaining battery life of the locate receiver for those embodiments that include a battery.

TABLE 2

Example Electronic Record For Locate Receiver		
Record # 1001	Service provider ID	0482
	User ID	4815
	Receiver ID	7362
	Receiver mode	Mode=Peak
	Timestamp data	12-Jul-2008; 09:35:15
	Geo-location data	2650.9348,N,08003.5057,W
	Signal strength (% of maximum)	85%
	Gain	45
	Signal frequency	1 kHz
	Facility depth	3.4 meters
	Facility type	Gas (yellow)
	Ground type	Pavement
	Battery strength data	85%
	Locate request data	Requestor=XYZ Construction Company, Requested service address=222 Main St, Orlando, FL

[0224] It should be appreciated that Table 2 represents only one non-limiting example of an electronic record of locate information which may be generated in accordance with the operation of a locate receiver, according to one embodiment. In particular, a single electronic record of locate information collected in connection with operation of a locate receiver may include multiple entries of a given data type. For example, while Table 2 illustrates an electronic record including a single GPS data point, it should be appreciated that multiple GPS data points may be taken and stored within a single electronic record. The multiple GPS data points may be taken in response to a single actuation event (e.g., single actuator pull by a technician), in response to multiple actuation events (e.g., multiple actuator pulls by a technician), automatic logging of data (e.g., based on magnetic field strength), or in other manners. Thus, multiple pieces of data may be collected for an electronic record of a locate operation, and it should be appreciated that any single electronic record may include multiple entries.

[0225] Thus, the geo-location(s) at which one or more facilities are detected may be obtained from these electronic records, and/or may be collected essentially in real-time as the locate operation is being performed. Once the geo-location data to be overlaid on the displayed information is determined, the process continues to optional act 903, where this geo-location data may be converted, if necessary, to the spatial reference frame used by the facilities map (or other image) from which the information displayed on the display 146 is derived.

[0226] As known in the relevant art, a geographic or “global” coordinate system (i.e., a coordinate system in which geographic locations on Earth are identified by a latitude and a longitude value, e.g., (LAT,LON)) may be used to identify geographic locations of detected facilities and a facility line indicated in facilities map information. In a “geocentric” global coordinate system (i.e., a coordinate system in which the Earth is modeled as a sphere), latitude is defined as the angle from a point on the surface of a sphere to the equatorial plane of the sphere, whereas longitude is defined as the angle east or west of a reference meridian between two geographical poles of the sphere to another meridian that passes through an arbitrary point on the surface of the sphere. Thus, in a geocentric coordinate system, the center of the Earth serves as a reference point that is the origin of the coordinate system. However, in actuality the Earth is not perfectly spherical, as it is compressed towards the center at the poles. Consequently, using a geocentric coordinate system can result in inaccuracies.

[0227] In view of the foregoing, the Earth is typically modeled as an ellipsoid for purposes of establishing a global coordinate system. The shape of the ellipsoid that is used to model the Earth and the way that the ellipsoid is fitted to the geoid of the Earth is called a “geodetic datum.” In a “geodetic” global coordinate system, the latitude of a point on the surface of the ellipsoid is defined as the angle from the equatorial plane to a line normal to the reference ellipsoid passing through the point, whereas the longitude of a point is defined as the angle between a reference plane perpendicular to the equatorial plane and a plane perpendicular to the equatorial plane that passes through the point. Thus, geodetic latitude and longitude of a particular point depends on the geodetic datum used.

[0228] A number of different geodetic global coordinate systems exist that use different geodetic datums, examples of which include WGS84, NAD83, NAD27, OSGB36, and ED50. As such, a geographic point on the surface of Earth may have a different latitude and longitude values in different coordinate systems. For example, a stop sign at the corner Maple St. and Main St. may have a latitude and longitude of (LAT₁, LON₁) in the WGS84 coordinate system, but may have a latitude and longitude of (LAT₂, LON₂) in the NAD83 coordinate system (where LAT₁≠LAT₂ and/or LON₁≠LON₂). Thus, when comparing one geographic point to another geographic point to determine the distance between them, it is desirable to have both geographic points in the same global coordinate system.

[0229] Additionally, when determining a geographic location based on information derived from a map (e.g., a facilities map), the coordinate system provided by the map may not be a global coordinate system, but rather may be a “projected” coordinate system. As appreciated in the relevant art, representing the curved surface of the Earth on a flat surface or plane is known as a “map projection.” Representing a curved surface in two dimensions causes distortion in shape, area, distance, and/or direction. Different map projections cause different types of distortions. For example, a projection could maintain the area of a feature but alter its shape. A map projection defines a relation between spherical coordinates on the globe (i.e., longitude and latitude in a global coordinate system) and flat planar x,y coordinates (i.e., a horizontal and vertical distance from a point of origin) in a projected coordinate system.

dinate system. A facilities map may provide geographic location information in one of several possible projected coordinate systems.

[0230] Thus, to overlay geo-location data (e.g., obtained from the location tracking system **130** of the locate receiver) on displayed facilities map information (or other image information), it is desirable to have the geo-location data and the facilities map information represented in the same geodetic global coordinate system or projected coordinate system (projected from the same geodetic geographical coordinate system). For example, in some embodiments, the geo-location data points obtained by the location tracking system of the locate receiver may be provided as geo-location data in the WGS84 coordinate system (i.e., the coordinate system typically used by GPS equipment), whereas the facilities map information may be expressed in the NAD83 coordinate system. Thus, at act **903**, the geo-location data coordinates provided by the location tracking system of the locate receiver may be converted to the NAD83 coordinate system so that they may be appropriately overlaid on the displayed facilities map information.

[0231] The process next continues to act **905**, where the data, converted if/as appropriate, may be overlaid on the information displayed on display **146**, such that display **146** displays both the facilities map/image information and the overlaid data. For example, if the technician detected an underground facility at 2650.9273,N,08003.5193,W (decimal degrees) in the coordinate system used by the facilities map, an electronic detection mark may be overlaid on the displayed facilities map at the portion of the facilities map that corresponds to 2650.9273,N,08003.5193,W. Similarly, if the current location of the locate receiver is 2680.5243,N,08043.4193,W in the coordinate system used by the facilities map, then a “you are here” icon may be overlaid on the displayed facilities map at the portion of the facilities map that corresponds to 2680.5243,N,08043.4193,W.

[0232] Any one of a number of different techniques may be used to overlay data on the displayed facilities map or image. In some embodiments, the data to be visually rendered on the facilities map or image is mapped to a display field of the display device to ensure that the geo-location data for the data to be overlaid is displayed over the proper place on the displayed facilities map or image. For example, in one exemplary implementation, a transformation may be derived using information relating to the available display field (e.g., a reference coordinate system using an appropriate scale for a given display field of a display device) to map data points in the geo-location data for the data to be overlaid to the available display field. Once such a transformation is derived, the data to be overlaid may be rendered in the display field by applying the transformation to the geo-location data for the data to be overlaid.

[0233] In the illustrative processes of FIGS. **14** and **15**, a separate facilities map may be selected for each facility type (or facility company). However, in some embodiments, rather than using a separate facilities map for each facility type or facility company, an aggregated facilities map or facilities map database may be generated by combining data from multiple facilities maps, and data from the aggregated facilities map database may be selected and displayed on the display of the locate receiver. For example, if gas lines, water lines, and power lines are to be detected during a locate and/or marking operation in a particular location, an aggregated facilities map database may be generated by accessing the

facilities map from the gas company for the location, the facilities map from the water company for the location, and the facilities map from the electric company for the location, extracting information about the location of map features (e.g., facility lines, streets, and/or other map features) from each of these facilities maps, converting the locations to a common frame of reference (e.g., using the techniques discussed above), and combining the extracted features into a database (e.g., from which a single aggregated map may be derived). Thus, rather than performing the process of FIG. **14** or **15** three times with three separate facilities maps (i.e., once using the gas facilities map, once using the water facilities map, and once using the electric facilities map), the aggregated facilities map may be used each time.

[0234] As with a facilities map for a single type of facility, in some embodiments, an electronic representation of underground facilities locations detected by a locate receiver (one or more electronic detection marks), an electronic representation of the current location of the technician (e.g., a you are here icon), or other information may be generated and rendered visually (i.e., overlaid) on the aggregated facilities map.

[0235] In some embodiments, the map or image data and the data to be overlaid (e.g., the electronic representation of underground facilities locations detected by a locate receiver or the electronic representation of the current location of the technician), may be displayed as separate “layers” of the visual rendering, such that a viewer of the visual rendering may turn on and turn off displayed data based on a categorization of the displayed data. For example, all facilities map or image data may be categorized generally under one layer designation (e.g., “Reference”), and independently enabled or disabled for display (e.g., hidden) accordingly. Similarly, all overlaid data may be categorized generally under another layer designation (e.g., “Field”) and independently enabled or disabled for display accordingly. Respective layers may be enabled or disabled for display in any of a variety of manners; for example, in one implementation, a “layer directory” or “layer legend” pane may be included in the display field (or as a separate window selectable from the display field of the visual rendering), showing all available layers, and allowing a viewer to select each available layer to be either displayed or hidden, thus facilitating comparative viewing of layers.

[0236] Furthermore, any of the above-mentioned general categories for layers may have sub-categories for sub-layers, such that each sub-layer may also be selectively enabled or disabled for viewing by a viewer. For example, under the general layer designation of “Field,” different facility types that may have been detected (and indicated in the field data by utility type/color, for example) may be categorized under different sub-layer designations (e.g., “Field-Electric;” “Field-Gas;” etc.); in this manner, a viewer may be able to hide the electric field data while viewing the gas field data, or vice versa, in addition to having the option to view or hide all field data.

[0237] In some embodiments, a variety of other sub-layers may be used. For example, sub-layers may be provided for certain types of map metadata. In one example, landmarks (e.g., poles, pedestals, curbs, hydrants, street lights, and/or other types of landmarks) may be a separate sub-layer that can be toggled on and off from the display. In another example, sub-layers for a particular facility type may be provided. As one example, within the sub-layer “Field-Electric,” a sub-layer may be provided for aerial electric lines, and another sub-layer may be provided for underground electric lines. As

another example, for a sub-layer for telephone lines (e.g., “Field-Telephone”), sub-layers may be provided for the type of material used. For example, one sub-layer may be provided for copper telephone lines, while another sub-layer may be provided for fiber lines.

[0238] Similarly, in embodiments in which an aggregated facilities map is displayed on the display device, the “Reference” layer may have sub-layers for each facility type in the aggregated facilities map. That is, each facility type in the aggregated facilities map may have a different sub-layer designation, such that a viewer may be able to individually select which sub-layers are displayed on the display device. For example, if an aggregated facilities map includes information from a gas facilities map, an electric facilities map, and a cable TV (CATV) facilities map, the data from the gas facilities map, the data from the electric facilities map, and the data from the CATV facilities may each be a separate sub-layer. As such, the viewer may be able to select which of these layers he or she wishes to be displayed on the display, and which he or she wishes to be hidden. Virtually any characteristic of the information available for display may serve to categorize the information for purposes of displaying layers or sub-layers.

[0239] FIG. 16 shows a generic display device **3000** having a display field **3005** with exemplary content for purposes of explaining some concepts germane to display layers, according to one embodiment. For example, all locate information may be categorized generally under one layer designation **3030** (“locate layer”) and independently enabled or disabled for display accordingly, all landmark information may be categorized generally under yet another layer designation **3040** (“landmark layer”) and independently enabled or disabled for display accordingly, and all reference information may be categorized generally under yet another layer designation **3050** (“reference layer”) and independent enabled or disabled for display. Respective layers may be enabled or disabled for display in any of a variety of manners; for example, in one implementation, a “layer directory” or “layer legend” pane **3010** may be included in the display field **3005** (or as a separate window selectable from the display field of the visual rendering), showing all available layers, and allowing a viewer to select each available layer to be either displayed or hidden, thus facilitating comparative viewing of layers.

[0240] Furthermore, any of the above-mentioned general categories for layers may have sub-categories for sub-layers, such that each sub-layer may also be selectively enabled or disabled for viewing by a viewer. For example, under the general layer designation of “locate layer,” different facility types that may have been detected during a locate and/or marking operation (and indicated in the locate information by color, for example) may be categorized under different sub-layer designations (e.g., designation **3032** for “locate layer-electric;” designation **3034** for “locate layer-gas;” etc.); in this manner, a viewer may be able to hide only the electric locate information while viewing the gas locate information, or vice versa, in addition to having the option to view or hide all locate information. Under the layer designation of “landmark layer” different types of landmarks may be categorized under different sub-layer designations (e.g., designation **3042** for water/sewer landmarks, designation **3044** for cable TV landmarks, and designation **3045** for buildings). Under the layer designation of “reference layer” different types of reference information may be categorized under different sub-

layer designations (e.g., designation **3052** for base map information, designation **3054** for dig area indicators, designation **3056** for facility lines).

[0241] As shown in the example of FIG. 16, of the locate, landmark, and reference layers, only the electric sub-layer of the locate layer and the buildings sub-layer of the landmark layer are enabled for display. Accordingly, in FIG. 16, only the electronic detection marks **1010** indicating where a power line was detected and building **950** appear in the electronic rendering **1000A** shown in FIG. 16.

[0242] Virtually any characteristic of the information available for display may serve to categorize the information for purposes of displaying layers or sub-layers. In particular, with respect to information obtained during performance of a locate and/or marking operation, any of a variety of exemplary constituent elements of such information (e.g., timing information, geographic information, service-related information, ticket information, facility type information) may be categorized as a sub-layer, and one or more sub-layers may further be categorized into constituent elements for selective display (e.g., as sub-sub-layers). For example, timing information may be used to categorize the locate information based on a time at which a particular facility line was detected, such that one sub-layer may include an electronic representation of the locations at which a facility line was detected during a particular time window. Geographic information may be used to categorize the locate information based on a location at which a facility line was detected, so that one sub-layer may include electronic representations of the locations at which facility lines were detected for a particular geographic area.

[0243] Service-related information may include, for example, a service-provider identifier indicative of a service-provider overseeing the locate and/or marking operation, a technician identifier representing a technician that performs the locate operation and/or the marking operation, a device identifier representing a device used by the technician during the locate operation and/or the marking operation, and a status identifier representing an operating status of the at least one device. Any such service-related information may be used to categorize the locate information into one or more sub-layers.

[0244] Ticket information may include a ticket number identifying the ticket, a party identifier representing a party requesting the locate and/or the marking operation, a facility identifier representing a type and/or number of one or more facilities to be detected and/or marked in the locate and/or the marking operation, and/or a ground type identifier representing a ground type for a work site and/or dig area at which the locate and/or the marking operation is performed. Any such ticket information may be used to categorize the marking information into one or more sub-layers.

[0245] Similarly, with respect to the “Reference” layer, virtually any characteristic of the information available for display in this layer may serve to categorize the information for purposes of displaying sub-layers. For example, landmarks, particular types of landmarks, particular types of facility lines, dig area indicators (e.g., virtual white lines), facility lines owned by a particular entity, and/or facility lines in a particular geographic area may each be a separate sub-layer.

[0246] In some embodiments, processor **118** may automatically select which sub-layers in the “Reference” layer and/or the “Field” layer are displayed. For example, in some embodiments, processor **118** may automatically select par-

particular sub-layers to be displayed based on the type of facility being located. As discussed above, processor 118 may determine the type of facility being located in a variety of ways, including for example, based on user input identifying the type of facility being located. Thus, on this basis, processor 118 may automatically select certain sub-layers to be displayed and may select certain other sub-layers to not be displayed. For example, if a technician indicates that electric lines are being detected, processor 118 may automatically select sub-layers related to electric lines to be displayed, and may select sub-layers not related to electric lines to not be displayed.

[0247] In general, it should be appreciated that any constituent element of information from the field (e.g., locate information and/or landmark information) may be used as a basis for automatically selecting/enabling for display one or more sub-layers of reference/image information. For example, if landmark information indicates that acquired landmark geo-location data is associated with a hydrant, a “water facilities” sub-layer and/or a “water landmarks” sub-layer may be automatically selected from the “Reference” layer for display in the display field. Similarly, if locate information indicates that a gas main is being detected, a “gas facilities” sub-layer and/or a “gas landmarks” sub-layer may be automatically selected from the “Reference” layer for display in the display field. The foregoing are merely illustrative examples of automatic selection/enabling of Reference sub-layers, and the inventive concepts discussed herein are not limited in these respects.

V. CONCLUSION

[0248] While various inventive embodiments have been described and illustrated herein, those of ordinary skill in the art will readily envision a variety of other means and/or structures for performing the function and/or obtaining the results and/or one or more of the advantages described herein, and each of such variations and/or modifications is deemed to be within the scope of the inventive embodiments described herein. More generally, those skilled in the art will readily appreciate that all parameters, dimensions, materials, and configurations described herein are meant to be exemplary and that the actual parameters, dimensions, materials, and/or configurations will depend upon the specific application or applications for which the inventive teachings is/are used. Those skilled in the art will recognize, or be able to ascertain using no more than routine experimentation, many equivalents to the specific inventive embodiments described herein. It is, therefore, to be understood that the foregoing embodiments are presented by way of example only and that, within the scope of the appended claims and equivalents thereto, inventive embodiments may be practiced otherwise than as specifically described and claimed. Inventive embodiments of the present disclosure are directed to each individual feature, system, article, material, kit, and/or method described herein. In addition, any combination of two or more such features, systems, articles, materials, kits, and/or methods, if such features, systems, articles, materials, kits, and/or methods are not mutually inconsistent, is included within the inventive scope of the present disclosure.

[0249] The above-described embodiments can be implemented in any of numerous ways. For example, the embodiments may be implemented using hardware, software or a combination thereof. When implemented in software, the software code can be executed on any suitable processor or

collection of processors, whether provided in a single computer or distributed among multiple computers.

[0250] Further, it should be appreciated that a computer may be embodied in any of a number of forms, such as a rack-mounted computer, a desktop computer, a laptop computer, or a tablet computer. Additionally, a computer may be embedded in a device not generally regarded as a computer but with suitable processing capabilities, including a Personal Digital Assistant (PDA), a smart phone or any other suitable portable or fixed electronic device.

[0251] Also, a computer may have one or more input and output devices. These devices can be used, among other things, to present a user interface. Examples of output devices that can be used to provide a user interface include printers or display screens for visual presentation of output and speakers or other sound generating devices for audible presentation of output. Examples of input devices that can be used for a user interface include keyboards, and pointing devices, such as mice, touch pads, and digitizing tablets. As another example, a computer may receive input information through speech recognition or in other audible format.

[0252] Such computers may be interconnected by one or more networks in any suitable form, including a local area network or a wide area network, such as an enterprise network, and intelligent network (IN) or the Internet. Such networks may be based on any suitable technology and may operate according to any suitable protocol and may include wireless networks, wired networks or fiber optic networks.

[0253] The various methods or processes outlined herein may be coded as software that is executable on one or more processors that employ any one of a variety of operating systems or platforms. Additionally, such software may be written using any of a number of suitable programming languages and/or programming or scripting tools, and also may be compiled as executable machine language code or intermediate code that is executed on a framework or virtual machine.

[0254] In this respect, various inventive concepts may be embodied as a computer readable storage medium (or multiple computer readable storage media) (e.g., a computer memory, one or more floppy discs, compact discs, optical discs, magnetic tapes, flash memories, circuit configurations in Field Programmable Gate Arrays or other semiconductor devices, or other non-transitory medium or tangible computer storage medium) encoded with one or more programs that, when executed on one or more computers or other processors, perform methods that implement the various embodiments of the invention discussed above. The computer readable medium or media can be transportable, such that the program or programs stored thereon can be loaded onto one or more different computers or other processors to implement various aspects of the present invention as discussed above.

[0255] The terms “program” or “software” are used herein in a generic sense to refer to any type of computer code or set of computer-executable instructions that can be employed to program a computer or other processor to implement various aspects of embodiments as discussed above. Additionally, it should be appreciated that according to one aspect, one or more computer programs that when executed perform methods of the present invention need not reside on a single computer or processor, but may be distributed in a modular fashion amongst a number of different computers or processors to implement various aspects of the present invention.

[0256] Computer-executable instructions may be in many forms, such as program modules, executed by one or more computers or other devices. Generally, program modules include routines, programs, objects, components, data structures, etc. that perform particular tasks or implement particular abstract data types. Typically the functionality of the program modules may be combined or distributed as desired in various embodiments.

[0257] Also, data structures may be stored in computer-readable media in any suitable form. For simplicity of illustration, data structures may be shown to have fields that are related through location in the data structure. Such relationships may likewise be achieved by assigning storage for the fields with locations in a computer-readable medium that convey relationship between the fields. However, any suitable mechanism may be used to establish a relationship between information in fields of a data structure, including through the use of pointers, tags or other mechanisms that establish relationship between data elements.

[0258] Also, various inventive concepts may be embodied as one or more methods, of which an example has been provided. The acts performed as part of the method may be ordered in any suitable way. Accordingly, embodiments may be constructed in which acts are performed in an order different than illustrated, which may include performing some acts simultaneously, even though shown as sequential acts in illustrative embodiments.

[0259] All definitions, as defined and used herein, should be understood to control over dictionary definitions, definitions in documents incorporated by reference, and/or ordinary meanings of the defined terms.

[0260] The indefinite articles “a” and “an,” as used herein in the specification and in the claims, unless clearly indicated to the contrary, should be understood to mean “at least one.”

[0261] The phrase “and/or,” as used herein in the specification and in the claims, should be understood to mean “either or both” of the elements so conjoined, i.e., elements that are conjunctively present in some cases and disjunctively present in other cases. Multiple elements listed with “and/or” should be construed in the same fashion, i.e., “one or more” of the elements so conjoined. Other elements may optionally be present other than the elements specifically identified by the “and/or” clause, whether related or unrelated to those elements specifically identified. Thus, as a non-limiting example, a reference to “A and/or B”, when used in conjunction with open-ended language such as “comprising” can refer, in one embodiment, to A only (optionally including elements other than B); in another embodiment, to B only (optionally including elements other than A); in yet another embodiment, to both A and B (optionally including other elements); etc.

[0262] As used herein in the specification and in the claims, “or” should be understood to have the same meaning as “and/or” as defined above. For example, when separating items in a list, “or” or “and/or” shall be interpreted as being inclusive, i.e., the inclusion of at least one, but also including more than one, of a number or list of elements, and, optionally, additional unlisted items. Only terms clearly indicated to the contrary, such as “only one of” or “exactly one of,” or, when used in the claims, “consisting of,” will refer to the inclusion of exactly one element of a number or list of elements. In general, the term “or” as used herein shall only be interpreted as indicating exclusive alternatives (i.e. “one or the other but not both”) when preceded by terms of exclusiv-

ity, such as “either,” “one of,” “only one of,” or “exactly one of.” “Consisting essentially of,” when used in the claims, shall have its ordinary meaning as used in the field of patent law.

[0263] As used herein in the specification and in the claims, the phrase “at least one,” in reference to a list of one or more elements, should be understood to mean at least one element selected from any one or more of the elements in the list of elements, but not necessarily including at least one of each and every element specifically listed within the list of elements and not excluding any combinations of elements in the list of elements. This definition also allows that elements may optionally be present other than the elements specifically identified within the list of elements to which the phrase “at least one” refers, whether related or unrelated to those elements specifically identified. Thus, as a non-limiting example, “at least one of A and B” (or, equivalently, “at least one of A or B,” or, equivalently “at least one of A and/or B”) can refer, in one embodiment, to at least one, optionally including more than one, A, with no B present (and optionally including elements other than B); in another embodiment, to at least one, optionally including more than one, B, with no A present (and optionally including elements other than A); in yet another embodiment, to at least one, optionally including more than one, A, and at least one, optionally including more than one, B (and optionally including other elements); etc.

[0264] In the claims, as well as in the specification above, all transitional phrases such as “comprising,” “including,” “carrying,” “having,” “containing,” “involving,” “holding,” “composed of,” and the like are to be understood to be open-ended, i.e., to mean including but not limited to. Only the transitional phrases “consisting of” and “consisting essentially of” shall be closed or semi-closed transitional phrases, respectively, as set forth in the United States Patent Office Manual of Patent Examining Procedures, Section 2111.03.

What is claimed is:

1. A locate receiver to detect a presence or an absence of an underground facility, the locate receiver comprising:
 - a housing;
 - an RF antenna for receiving a magnetic field and outputting an output signal;
 - a processing circuit, for receiving the output signal from the RF antenna and determining a magnetic field strength of the magnetic field;
 - a display device coupled to the housing;
 - at least one memory; and
 - at least one processor, coupled to the processing circuit, the display device and the at least one memory, configured to display on the display device a map image that is generated based on first map data selected by the at least one processor.
2. The locate receiver of claim 1, wherein the processor is configured to obtain at least a portion of the first map data from a remote device and store the at least the portion of the first map data in the at least one memory.
3. The locate receiver of claim 2, wherein the at least the portion of the first map data comprises the at least one map image.
4. The locate receiver of claim 1, wherein the at least one processor is configured to generate the map image based on the portion of the first map data.
5. The locate receiver of claim 1, wherein the at least one memory stores map data including the first map data and wherein the at least one processor is configured to select the first map data in response to a user input.

6. The locate receiver of claim 1, wherein the at least one memory stores map data including the first map data and wherein the at least one processor is configured to select the first map data in response to information provided by at least one sensor.

7. The locate receiver of claim 1, wherein at least one memory stores map data including the first map data and wherein the at least one processor is configured to select the first map data in response to a user input and information provided by at least one sensor.

8. The locate receiver of claim 7, wherein the at least one sensor comprises a global position system (GPS) receiver that is coupled to the housing, and wherein the information provided by the at least one sensor comprises information indicative of a geographic location of the locate receiver, and wherein the at least one processor is configured to select the first map data based at least in part on the geographic location of the locate receiver.

9. The locate receiver of claim 8, wherein the at least one sensor comprises an electronic compass, and wherein the information provided by the at least one sensor comprises information indicative of a heading of the locate receiver, and wherein the at least one processor is configured to select the first map data based at least in part on the heading of the locate receiver.

10. The locate receiver of claim 1, wherein the at least one processor is configured to select the first map data based, at least in part, on information obtained from a ticket associated with a locate operation.

11. The locate receiver of claim 10, wherein the information obtained from the ticket comprises an address at which the locate operation is requested to be performed.

12. The locate receiver of claim 11, wherein the information obtained from the ticket comprises at least one member code indicative of a facility type to be located during performance of the locate operation.

13. The locate receiver of claim 12, wherein the information obtained from the ticket comprises information identifying an entity that requested performance of the locate operation.

14. The locate receiver of claim 1, wherein the at least one processor is configured to select the first map data based, at least in part, on a virtual white line image that indicates a location at which excavation is planned.

15. The locate receiver of claim 1, wherein the first map data comprises first facilities map data, wherein the at least one memory stores facilities map data including the first facilities map data, and wherein the at least one processor is configured to select the first facilities map data from the facilities map data stored in the at least one memory.

16. The locate receiver of claim 1, wherein the at least one processor is configured to select an orientation at which to display, on the display device, the map image, based at least in part on heading information indicative of a direction in which the locate receiver is moving.

17. The locate receiver of claim 16, further comprising at least one electronic compass, and wherein the at least one processor is configured to determine the heading information from the at least one electronic compass.

18. The locate receiver of claim 16, further comprising at least one global positioning system (GPS) receiver, and wherein the at least one processor is configured to determine the heading information using information from the at least one GPS receiver.

19. The locate receiver of claim 1, wherein the at least one processor is configured to translate, rotate and/or zoom the map image.

20. The locate receiver of claim 20, wherein the at least one processor is configured to translate, rotate and/or zoom the map image in response to user input indicating a desired orientation or zoom of the map image.

21. The locate receiver of claim 1, wherein the map image is a first map image, and wherein the at least one processor is configured to cause the first map image to be replaced on the display device with a second map image that is generated from second map data, in response to a change in a geographic location of the locate receiver.

22. The locate receiver of claim 21, wherein the second map data comprises information not included in the first map data.

23. A method for displaying information on a locate receiver having a housing, an RF antenna for receiving a magnetic field and outputting an output signal, a processing circuit, for receiving the output signal from the RF antenna and determining a magnetic field strength of the magnetic field, a display device coupled to the housing, at least one memory; and at least one processor, coupled to the processing circuit, the display device and the at least one memory, the method comprising:

displaying on the display device a map image that is generated based on first map data selected by the at least one processor.

24. The method of claim 23, further comprising:

obtaining at least a portion of the first map data from a remote device; and

storing the at least the portion of the first map data in the at least one memory.

25. The method of claim 24, wherein the at least the portion of the first map data comprises the at least one map image.

26. The method of claim 23, wherein the at least one processor is configured to generate the map image based on the portion of the first map data.

27. The method of claim 23, wherein the at least one memory stores map data including the first map data and wherein the method further comprises:

selecting the first map data in response to a user input.

28. The method of claim 23, wherein the at least one memory stores map data including the first map data and wherein the method further comprises:

selecting the first map data in response to information provided by at least one sensor.

29. The method of claim 23, wherein the at least one memory stores map data including the first map data and wherein the method further comprises:

selecting the first map data in response to a user input and information provided by at least one sensor.

30. The method of claim 29, wherein the at least one sensor comprises a global position system (GPS) receiver that is coupled to the housing, and wherein the information provided by the at least one sensor comprises information indicative of a geographic location of the locate receiver, and wherein the method further comprises:

selecting the first map data based at least in part on the geographic location of the locate receiver.

31. The method of claim 30, wherein the at least one sensor comprises an electronic compass, and wherein the informa-

tion provided by the at least one sensor comprises information indicative of a heading of the locate receiver, and wherein the method further comprises:

selecting the first map data based at least in part on the heading of the locate receiver.

32. The method of claim of claim **29**, further comprising: selecting the first map based, at least in part, on user input indicative of type of facility being located.

33. The method of claim **24**, wherein the method further comprises:

selecting the first map data, at least in part, on information obtained from a ticket associated with a locate operation.

34. The method of claim **33**, wherein the information obtained from the ticket comprises an address at which the locate operation is requested to be performed.

35. The method of claim **33**, wherein the information obtained from the ticket comprises at least one member code indicative of a facility type to be located during performance of the locate operation.

36. The method of claim **35**, wherein the information obtained from the ticket comprises information identifying an entity that requested performance of the locate operation.

37. The method of claim **23**, further comprising:

selecting the first map data based, at least in part, on a virtual white line image that indicates a location at which excavation is planned.

38. The method of claim **23**, wherein the first map data comprises first facilities map data, wherein the at least one memory stores facilities map data including the first facilities map data, and wherein the method further comprises:

selecting the first facilities map data from the facilities map data stored in the at least one memory.

39. The method of claim **23**, further comprising:

select an orientation at which to display, on the display device, the map image, based at least in part on heading information indicative of a direction in which the locate receiver is moving.

40. The method of claim **39**, wherein the locate receiver further comprises at least one electronic compass, and wherein the method further comprises:

determining the heading information from the at least one electronic compass.

41. The method of claim **39**, wherein the locate receiver further comprises at least one global positioning system (GPS) receiver, and wherein the method further comprises:

determining the heading information using information from the at least one GPS receiver.

42. The method of claim **23**, further comprising:

translating, rotating and/or zooming the map image.

43. The method of claim **42**, wherein the act of translating, rotating and/or zooming the map image is performed in response to user input indicating a desired orientation or zoom of the map image.

44. The method of claim **23**, wherein the map image is a first map image, and wherein the method further comprises:

in response to a change in a geographic location of the locate receiver, replacing the first map image on the display device with a second map image that is generated from second map data.

45. The method of claim **44**, wherein the second map data comprises information not included in the first map data.

46. At least one computer-readable storage medium encoded with instructions that, when executed on at least one processor in a locate receiver having a housing, an RF antenna for receiving a magnetic field and outputting an output signal, a processing circuit, for receiving the output signal from the RF antenna and determining a magnetic field strength of the magnetic field, a display device coupled to the housing, at least one memory; and at least one processor, coupled to the processing circuit, the display device and the at least one memory, causes the at least one processor to perform a method comprising:

displaying on the display device a map image that is generated based on first map data selected by the at least one processor.

* * * * *