

(19) World Intellectual Property Organization
International Bureau



(43) International Publication Date
26 February 2009 (26.02.2009)

PCT

(10) International Publication Number
WO 2009/026339 A2

(51) International Patent Classification:
G01N 27/26 (2006.01) *B01D 57/00* (2006.01)

(74) Common Representative: E. Eric Mills; Ward & Smith, P.A., 1001 College Court, Post Office Box 867, New Bern, North Carolina, 28563-0867 (US).

(21) International Application Number:
PCT/US2008/073673

(81) Designated States (unless otherwise indicated, for every kind of national protection available): AE, AG, AL, AM, AO, AT, AU, AZ, BA, BB, BG, BH, BR, BW, BY, BZ, CA, CH, CN, CO, CR, CU, CZ, DE, DK, DM, DO, DZ, EC, EE, EG, ES, FI, GB, GD, GE, GH, GM, GT, HN, HR, HU, ID, IL, IN, IS, JP, KE, KG, KM, KN, KP, KR, KZ, LA, LC, LK, LR, LS, LT, LU, LY, MA, MD, ME, MG, MK, MN, MW, MX, MY, MZ, NA, NG, NI, NO, NZ, OM, PG, PH, PL, PT, RO, RS, RU, SC, SD, SE, SG, SK, SL, SM, ST, SV, SY, TJ, TM, TN, TR, TT, TZ, UA, UG, US, UZ, VC, VN, ZA, ZM, ZW.

(22) International Filing Date: 20 August 2008 (20.08.2008)

(25) Filing Language: English

(26) Publication Language: English

(30) Priority Data:
60/956,774 20 August 2007 (20.08.2007) US
60/980,503 17 October 2007 (17.10.2007) US

(71) Applicant (for all designated States except US): **ADVANCED LIQUID LOGIC, INC.** [US/US]; PO Box 14025, Research Triangle Park, North Carolina 27709 (US).

(84) Designated States (unless otherwise indicated, for every kind of regional protection available): ARIPO (BW, GH, GM, KE, LS, MW, MZ, NA, SD, SL, SZ, TZ, UG, ZM, ZW), Eurasian (AM, AZ, BY, KG, KZ, MD, RU, TJ, TM), European (AT, BE, BG, CH, CY, CZ, DE, DK, EE, ES, FI, FR, GB, GR, HR, HU, IE, IS, IT, LT, LU, LV, MC, MT, NL, NO, PL, PT, RO, SE, SI, SK, TR), OAPI (BF, BJ, CF, CG, CI, CM, GA, GN, GQ, GW, ML, MR, NE, SN, TD, TG).

(71) Applicant and
(72) Inventor: **PAIK, Philip** [US/US]; 1725 TW Alexander Dr. Unit 601, Durham, North Carolina 27703 (US).

Published:
— without international search report and to be republished upon receipt of that report

(72) Inventor; and
(75) Inventor/Applicant (for US only): **POLLACK, Michael** [US/US]; 1102 Hill Street, Durham, North Carolina 27709 (US).

(54) Title: MODULAR DROPLET ACTUATOR DRIVE

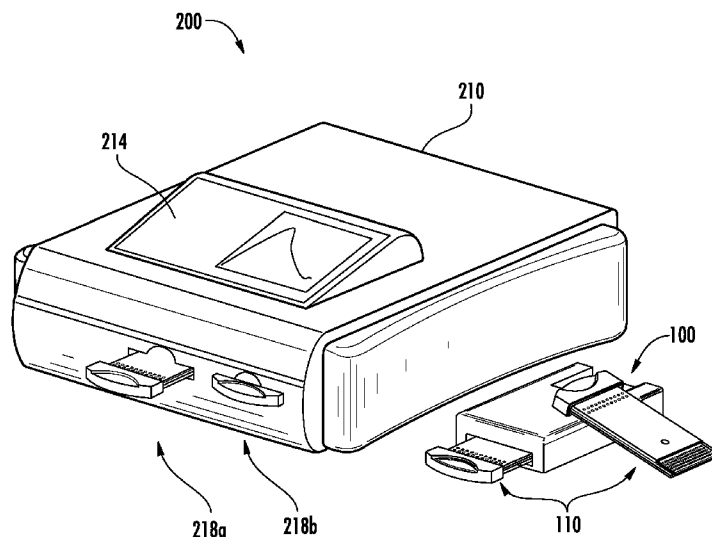

FIG. 2

(57) Abstract: The invention provides a droplet actuator drive. In certain embodiments, the droplet actuator drive may include a detection apparatus for sensing a property of a droplet on a droplet actuator; circuitry for controlling the detection apparatus electronically coupled to the detection apparatus; a droplet actuator cartridge connector; circuitry for controlling a droplet actuator coupled to the droplet actuator connector; and/or a means for coupling the droplet actuator circuitry to a processor. Systems, kits and methods of conducting assays are also provided.

WO 2009/026339 A2

Modular Droplet Actuator Drive

1 Related Patent Application:

This application claims priority to U.S. Patent Application Nos. 60/980,503, filed on October 17, 2007, and 60/956,774, filed on August 20, 2007, both entitled “Modular droplet actuator drive,” the entire disclosures of which is incorporated herein by reference.

2 Background

Droplet actuators are used to conduct a wide variety of droplet operations. A droplet actuator typically includes two plates separated by a gap. The plates include electrodes for conducting droplet operations. The space is typically filled with a filler fluid that is immiscible with the fluid that is to be manipulated on the droplet actuator. The formation and movement of droplets is controlled by electrodes for conducting a variety of droplet operations, such as droplet transport and droplet dispensing. Because there are multiple types of assays that require multiple types of droplet actuator instrumentation, there is a need for flexible droplet actuator instruments that are capable of performing multiple types of assays.

3 Brief Description of the Invention

The invention provides a droplet actuator drive. In certain embodiments, the droplet actuator drive may include a detection apparatus for sensing a property of a droplet on a droplet actuator; circuitry for controlling the detection apparatus electronically coupled to the detection apparatus; a droplet actuator cartridge connector; circuitry for controlling a droplet actuator coupled to the droplet actuator connector; and/or a means for coupling the droplet actuator circuitry to a processor. The droplet actuator cartridge connector may be arranged so that when a droplet actuator cartridge is electronically coupled thereto, the droplet actuator cartridge is aligned with the detection apparatus; and the detection apparatus can sense the property of the droplet on a droplet actuator.

In some embodiments, the means for coupling the circuitry to a processor includes a set of connections for electrically coupling the circuitry to a computer, and/or means for wirelessly coupling the circuitry to a computer. The means for coupling the circuitry to a processor may

include a droplet actuator drive configured for insertion in and electronic coupling to a computer via a drive bay of a desktop or laptop computer. For example, the droplet actuator drive may be configured as a desktop drive.

In some cases, the droplet actuator cartridge connector comprises a slide-out tray, and electronically coupling the droplet actuator cartridge connector to the processor is accomplished by (i) opening the slide-out tray; (ii) inserting the droplet actuator cartridge into the slide-out tray; and (iii) closing the slide-out tray.

The droplet actuator drive may be provided in a configuration suitable for insertion into a memory stick slot. The droplet actuator drive may be provided in a configuration suitable for insertion into a USB port. The means for coupling the droplet actuator circuitry to a processor comprises a male USB connector integrated with the droplet actuator drive.

The droplet actuator drive may include two or more of the droplet actuator cartridge connectors. The two or more droplet actuator cartridge connectors may include two or more connectors each configured for a different droplet actuator cartridge specific for a different droplet actuator test type.

In some cases, the droplet actuator drive may include an output mechanism for providing output indicative of sensing by the detection apparatus of a property of a droplet on the droplet actuator.

The droplet actuator drive may also include means for coupling the detector circuitry to a processor.

In some cases, the droplet actuator cartridge connector includes a slot configured for insertion of a droplet actuator cartridge.

In some cases, the the detection apparatus comprises a sensor for sensing photons emitted from and/or transmitted through a droplet on the droplet actuator.

In some cases, a droplet actuator cartridge electronically coupled to the droplet actuator cartridge connector.

The droplet actuator cartridge may include an optically transparent region which aligns with the detection apparatus, permitting sensing of a property of a droplet on a droplet actuator.

In some cases, the droplet actuator drive also includes reagents for a predetermined assay type pre-loaded on the droplet actuator cartridge and a sample loaded on the droplet actuator cartridge prior to insertion into the slot. For example, in some cases, the reagents include nucleic acid amplification reagents; immunoassay reagents; and/or biochemistry reagents.

The invention also provides a system including a droplet actuator drive and a processor coupled to the means for coupling the detector circuitry to a processor. The system may be programmed to control the droplet actuator and/or detection apparatus. The processor may be a component of a computer selected from the group consisting of desktop computers, laptop computers, and handheld computers. The system may also include a droplet actuator cartridge electronically coupled to the droplet actuator cartridge connector.

In other embodiment, the invention includes a kit. The kit may, for example, include packaged elements, such as a droplet actuator drive. The kit may include a droplet actuator drive along with one or more droplet actuators. The kit may include droplet actuators along with one or more reagents for loading on the droplet actuators. For example, the kit may include beads for conducting an assay using the droplet actuator cartridge. The beads may be provided pre-loaded on the droplet actuator cartridge.

The kit may include instructions for using the kit. The instructions may be electronically stored on an electronic storage medium associated with the cartridge such that when coupled to a droplet actuator drive, the instructions are displayed on an output device associated with the droplet actuator drive and or a system comprising the droplet actuator drive.

The invention also provides methods of conducting assays. For example, a method may involve providing a droplet actuator drive of the invention; electronically coupling the droplet actuator drive to a computer processor; coupling a droplet actuator cartridge to a droplet actuator cartridge connector, the cartridge comprising reagent sample for an assay protocol; executing software using the computer processor to effect droplet operations steps and other steps for conducting the assay. For example, the steps may include executing steps in the assay protocol; sensing a

property of an assay droplet; and/or displaying an output indicative of the property of the assay droplet.

In some cases, the methods of the invention include conducting one or more droplet operations using droplets comprising one or more beads; conducting one or more droplet operations using droplets comprising one or more biological cells; conducting one or more dispensing or splitting droplet operations using droplets comprising beads; conducting one or more dispensing or splitting droplet operations using droplets comprising biological cells; conducting one or more dispensing or splitting droplet operations using droplets comprising viable biological cells; conducting one or more washing operations using magnetically responsive beads; conducting one or more washing operations using substantially non-magnetically responsive beads.

4 Definitions

As used herein, the following terms have the meanings indicated.

“Activate” with reference to one or more electrodes means effecting a change in the electrical state of the one or more electrodes which results in a droplet operation.

“Bead,” with respect to beads on a droplet actuator, means any bead or particle that is capable of interacting with a droplet on or in proximity with a droplet actuator. Beads may be any of a wide variety of shapes, such as spherical, generally spherical, egg shaped, disc shaped, cubical and other three dimensional shapes. The bead may, for example, be capable of being transported in a droplet on a droplet actuator; configured with respect to a droplet actuator in a manner which permits a droplet on the droplet actuator to be brought into contact with the bead, on the droplet actuator and/or off the droplet actuator. Beads may be manufactured using a wide variety of materials, including for example, resins, and polymers. The beads may be any suitable size, including for example, microbeads, microparticles, nanobeads and nanoparticles. In some cases, beads are magnetically responsive; in other cases beads are not significantly magnetically responsive. For magnetically responsive beads, the magnetically responsive material may constitute substantially all of a bead or one component only of a bead. The remainder of the bead may include, among other things, polymeric material, coatings, and moieties which permit attachment of an assay reagent. Examples of suitable magnetically responsive beads are described in U.S. Patent Publication No. 2005-0260686, entitled, “Multiplex flow assays

preferably with magnetic particles as solid phase,” published on November 24, 2005, the entire disclosure of which is incorporated herein by reference for its teaching concerning magnetically responsive materials and beads. It should also be noted that various droplet operations described herein which can be conducted using beads can also be conducted using biological cells.

“Droplet” means a volume of liquid on a droplet actuator that is at least partially bounded by filler fluid. For example, a droplet may be completely surrounded by filler fluid or may be bounded by filler fluid and one or more surfaces of the droplet actuator. Droplets may take a wide variety of shapes; nonlimiting examples include generally disc shaped, slug shaped, truncated sphere, ellipsoid, spherical, partially compressed sphere, hemispherical, ovoid, cylindrical, and various shapes formed during droplet operations, such as merging or splitting or formed as a result of contact of such shapes with one or more surfaces of a droplet actuator.

“Droplet operation” means any manipulation of a droplet on a droplet actuator. A droplet operation may, for example, include: loading a droplet into the droplet actuator; dispensing one or more droplets from a source droplet; splitting, separating or dividing a droplet into two or more droplets; transporting a droplet from one location to another in any direction; merging or combining two or more droplets into a single droplet; diluting a droplet; mixing a droplet; agitating a droplet; deforming a droplet; retaining a droplet in position; incubating a droplet; heating a droplet; vaporizing a droplet; cooling a droplet; disposing of a droplet; transporting a droplet out of a droplet actuator; other droplet operations described herein; and/or any combination of the foregoing. The terms “merge,” “merging,” “combine,” “combining” and the like are used to describe the creation of one droplet from two or more droplets. It should be understood that when such a term is used in reference to two or more droplets, any combination of droplet operations sufficient to result in the combination of the two or more droplets into one droplet may be used. For example, “merging droplet A with droplet B,” can be achieved by transporting droplet A into contact with a stationary droplet B, transporting droplet B into contact with a stationary droplet A, or transporting droplets A and B into contact with each other. The terms “splitting,” “separating” and “dividing” are not intended to imply any particular outcome with respect to size of the resulting droplets (i.e., the size of the resulting droplets can be the same or different) or number of resulting droplets (the number of resulting droplets may be 2, 3, 4, 5 or more). The term “mixing” refers to droplet operations which result in more homogenous distribution of one or more components within a droplet. Examples of “loading” droplet operations include microdialysis loading, pressure assisted loading, robotic loading, passive

loading, capillary loading, fingerstick loading (or in general loading from a source such as humans or animals (tail snips on mice)), and pipette loading. Droplet operations may be mediated by electrodes and/or electric fields, using a variety of techniques, such as, electrowetting and/or dielectrophoresis. In some cases, droplet operations are further facilitated by the use of hydrophilic and/or hydrophobic regions on surfaces and/or by physical obstacles.

“Washing” with respect to washing a magnetically responsive bead means reducing the amount of one or more substances in contact with the magnetically responsive bead or exposed to the magnetically responsive bead from a droplet in contact with the magnetically responsive bead. The reduction in the amount of the substance may be partial, substantially complete, or even complete. The substance may be any of a wide variety of substances; examples include target substances for further analysis, and unwanted substances, such as components of a sample, contaminants, and/or excess reagent. In some embodiments, a washing operation begins with a starting droplet in contact with a magnetically responsive bead, where the droplet includes an initial total amount of a substance. The washing operation may proceed using a variety of droplet operations. The washing operation may yield a droplet including the magnetically responsive bead, where the droplet has a total amount of the substance which is less than the initial amount of the substance. Other embodiments use substantially non-magnetically responsive beads, and immobilization may be achieved using various physical barriers, e.g., as described in U.S. Patent Application No. 60/957,717, filed on August 24, 2007, entitled “Bead manipulations in a droplet actuator,” the entire disclosure of which is incorporated herein by reference.

The terms “top” and “bottom,” when used, e.g., to refer to the top and bottom substrates of the droplet actuator, are used for convenience only; the droplet actuator is functional regardless of its position or orientation in space.

When a given component, such as a layer, region or substrate, is referred to herein as being disposed or formed “on” another component, that given component can be directly on the other component or, alternatively, intervening components (for example, one or more coatings, layers, interlayers, electrodes or contacts) can also be present. It will be further understood that the terms “disposed on” and “formed on” are used interchangeably to describe how a given component is positioned or situated in relation to another component. Hence, the terms “disposed on” and “formed on” are not intended to introduce any limitations relating to particular methods of material transport, deposition, or fabrication.

When a liquid in any form (e.g., a droplet or a continuous body, whether moving or stationary) is described as being “on”, “at”, or “over” an electrode, array, matrix or surface, such liquid could be either in direct contact with the electrode/array/matrix/surface, or could be in contact with one or more layers or films that are interposed between the liquid and the electrode/array/matrix/surface.

When a droplet is described as being “on” or “loaded on” a droplet actuator, it should be understood that the droplet is arranged on the droplet actuator in a manner which facilitates using the droplet actuator to conduct droplet operations on the droplet, the droplet is arranged on the droplet actuator in a manner which facilitates sensing of a property of or a signal from the droplet, and/or the droplet has been subjected to a droplet operation on the droplet actuator, e.g., a layer of filler fluid.

5 Description

The invention provides modular drive configurations for handling multiple types of assays. In one embodiment, the invention provides a standalone, assay-specific, droplet operations drive that is suitable for use with a corresponding assay-specific droplet actuator cartridge. In another embodiment, the invention provides a host instrument that is suitable for use with multiple types of assay-specific droplet operations drives. In yet other embodiments, droplet operations drives are provided that have standard computer form factors, which allow easy installation in any standard drive bay of any standard desktop or laptop computer or a handheld computer. The modular drive configurations provide flexible reuse of instruments, user configurability, and scalability.

5.1 Standalone Droplet Operations Drive

Figure 1 illustrates a perspective view of a non-limiting example of a standalone droplet operations drive 100. The drive may include specific detection and sensing apparatus, and may, thus, be suitable for a specific subset of assay types. The drive is configured for use with a certain corresponding assay-specific droplet actuator cartridge 110, which includes a corresponding assay-specific droplet actuator (not shown) that is installed therein and electronics for coupling the droplet actuator to the drive. In one example, droplet operations drive 100 and a corresponding droplet actuator cartridge 110 are designed for performing immunoassays and,

thus, the invention provides an immunoassay-specific droplet operations drive 100 and an immunoassay-specific droplet actuator cartridge 110. In another example, droplet operations drive 100 and a corresponding droplet actuator cartridge 110 are designed for performing polymerase chain reaction (PCR) assays and, thus, the invention provides a PCR-specific droplet operations drive 100 and a PCR-specific droplet actuator cartridge 110. In yet another example, droplet operations drive 100 and droplet actuator cartridge 110 are designed for performing biochemistry assays including DNA sequencing and, thus, the invention provides a biochemistry assay-specific droplet operations drive 100 and a biochemistry assay-specific droplet actuator cartridge 110.

Droplet operations drive 100 may include a body 114 for housing control circuitry (not shown) and detection mechanisms (not shown) that may be common to multiple assay-specific droplet actuator cartridges 110. For example, a PCR-specific droplet operations drive 100 houses PCR-specific control circuitry and PCR-specific detection mechanisms that may be used in common to multiple designs of PCR-specific droplet actuator cartridges 110.

Body 114 of droplet operations drive 100 may, for example, be formed of any suitably rigid and lightweight material, such as molded plastic or metal. Droplet operations drive 100 may be provided in a form factor that is suitably small to fit in a handheld device. In one example, body 114 is about 5 inches long, about 3 inches wide, and about 1 inch high so that it can fit into any standard multiwell plate reader for detection. In another example, the body may be in the form of a USB thumb drive or an SD card so that the cartridge can be directly inserted into a port on a computer. Additionally, certain analysis software (not shown) that drives the multiple types of droplet actuator cartridges 110 may be loaded on the hardware within droplet operations drive 100 and/or on an associated computer system that controls droplet operations drive 100.

Droplet actuator cartridge 110 may be installed in a slot 118 at one end of body 114. A set of power and signal I/O connectors (not shown) may be provided at the opposite end of body 114. A corresponding set of electrical connections (not shown) are provided inside the cavity formed by slot 118 of droplet operations drive 100 for connecting to the certain droplet actuator cartridge 110 that is installed therein. The cartridge may also contain magnets or electromagnets to enable magnetic operations and heaters & coolers to enable thermal operations.

Because droplet actuator cartridge 110 may be assay-specific, droplet actuator cartridge 110 may include an assay-specific droplet actuator (not shown) within a body 122. In one example, droplet actuator cartridge 110 is designed for performing immunoassays and, therefore, includes an immunoassay droplet actuator. In another example, a certain droplet actuator cartridge 110 is designed for performing DNA amplification assays and, therefore, includes a DNA amplification droplet actuator. In yet another example, droplet actuator cartridge 110 is designed for performing biochemistry assays and, therefore, includes a biochemistry assay droplet actuator, and may also include reagents. In yet another example, assay-specific reagents may be loaded on the droplet actuator and/or droplet actuator cartridge 110. In another embodiment, a combination cartridge is designed to perform a combination of biochemistry assays such as DNA amplification and immunoassays, DNA amplification and DNA sequencing and other combinations of biochemical assay types.

Body 122 of droplet actuator cartridge 110 may, for example, be formed of any suitably rigid and lightweight material, such as molded plastic or metal. Alternatively, body 122 of droplet actuator cartridge 110 may, for example, be formed of a heavy duty material that is suitable for field or military use. A grip 126 may be incorporated at one end of body 122 for easy handling of droplet actuator cartridge 110. Body 122 may also include a set of electrical connections 130, such as a set of conductive pads, for providing power or signal I/O to the droplet actuator arranged so that when the cartridge is installed, the contacts are electrically coupled with corresponding connections associated with the drive. Additionally, droplet actuator cartridge 110 may include a sample/reagent input 134, which is fluidly connected to the droplet actuator. In one example, sample/reagent input 134 includes openings that allow for easy pipetting of samples or reagents. In another example, the sample liquid may be directly “sipped” into the cartridge by capillary flow for further analysis. In this example, the openings may be sealable by an array of caps or by tape. Furthermore, droplet actuator cartridge 110 includes a detection area 138. Droplet actuator cartridge 110 may include detection area 138, which is arranged is such that it automatically aligns with a detector (not shown) within body 114 of droplet operations drive 100 when droplet actuator cartridge 110 is installed therein.

The design of slot 118 of droplet operations drive 100 in combination with the design of droplet actuator cartridge 110 may include a push-actuated connection. More specifically, droplet actuator cartridge 110 and slot 118 of droplet operations drive 100 may be designed so that

pushing droplet actuator cartridge 110 into slot 118 locks droplet actuator cartridge 110 in place and makes the electrical contacts.

By way of example, the use of droplet operations drive 100 in a DNA amplification assay application may be summarized as follows. A user electrically couples a certain DNA amplification-specific droplet operations drive 100 to a user interface device, such as a desktop or laptop computer; the user then selects a first type of assay-specific droplet actuator cartridge 110; loads a sample in the cartridge; inserts the first DNA amplification-specific droplet actuator cartridge 110 into slot 118 of the DNA amplification-specific droplet operations drive 100; executes the assay-specific protocol; and receives a first set of assay-specific assay results. Subsequently, the user removes the first assay-specific droplet actuator cartridge 110 from the assay-specific droplet operations drive 100; inserts a second type of assay-specific droplet actuator cartridge 110 into slot 118 of the DNA amplification-specific droplet operations drive 100; executes the assay-specific protocol; and receives a second set of assay-specific assay results. The above process may be repeated for a third, fourth, fifth, and so on, type of DNA amplification-specific droplet actuator cartridge 110. Alternatively, multiple assays and droplet operations drives may be operated in parallel, which is described further in the next section.

5.2 Host Instrument for Multiple Droplet Operations Drives

Figure 2 illustrates a perspective view of a non-limiting example of a host instrument 200, which provides a modular standalone configuration of droplet operations drives 100, which is suitable for use as, for example, a benchtop analyzer device. A body 210 of host instrument 200 may house a controller unit (not shown), which may include compact electronics for droplet control, and a detection unit (not shown), which may, for example, include a photomultiplier tube (PMT) for chemiluminescence detection, LED/APD for fluorescence detection, optional modular detection units that are available via fiber coupling, and any combinations thereof. Alternatively, the detection unit can include electrical connections for electrical readout of signals produced by droplets (electrochemical, amperometric, potentiometric, conductometric, impedance-based etc). The detection unit can also include means for detecting magnetism. The controller unit and detection unit may provide functionality for multiple types of assays, such as, but not limited to, immunoassays, DNA amplification assays, and biochemistry assays. Additionally, analysis software may be loaded on the hardware of host instrument 200 that is suitable of performing the

multiple types of assays. A user interface 214, such as a touch screen, is provided for operating host instrument 200.

Additionally, host instrument 200 includes one or more drive bays 218 (e.g., drive bays 218a and 218b). In one embodiment, drive bays 218 allow for swapping drives in any combination. In other embodiments, drive bays 218 may be specific to certain types of droplet actuator cartridges. For example, within drive bays 218 of host instrument 200 may be installed one or more immunoassay-specific droplet operations drives 100, one or more DNA amplification-specific droplet operations drives 100, one or more biochemistry assay-specific droplet operations drives 100, and any combinations thereof.

Body 210 of host instrument 200 may, for example, be formed of any suitably rigid and lightweight material, such as molded plastic or metal. Alternatively, body 210 of host instrument 200 may, for example, be formed of a heavy duty material that is suitable for field or military use. In one example, body 210 of host instrument 200 is about 12 inches long, about 12 inches wide, and about 3.5 inches high.

By way of example, a user may install an assay-specific droplet operations drive 100, which has a corresponding assay-specific droplet actuator cartridge 110 inserted therein, in drive bay 218a and execute an assay-specific analysis thereon. At the same time, a user may install an assay-specific droplet operations drive 100, which has a corresponding assay-specific droplet actuator cartridge 110 inserted therein, in drive bay 218b and execute an assay-specific analysis thereon. Host instrument 200 may operate in a standalone mode. Alternatively, host instrument 200 may be connected to an external computing device, such as described in Figure 3. The host instrument may also be a stack or a tower which incorporates multiple cartridges in a rack which is accessible for processing (such as fluid input and output) by robotics that are utilized in a high throughput environment.

Figure 3 illustrates a perspective view of a non-limiting example of a system 300 that includes a computing device 310, such as a standard desktop or laptop computer, along with its associated user interfaces 314, such as a display, keyboard, and mouse. Additionally, system 300 includes at least one host instrument 200 of Figure 2 that has a wired (e.g., USB or Firewire connection) or wireless (e.g., BluetoothTM or IEEE 802.11 technology) communication link to computing device 310. In one example, the analysis software that drives the one or more droplet actuator cartridges

110, which are installed in the respective droplet operations drives 100 of host instrument 200, resides on computing device 310.

5.3 Droplet Operations Drives Having Standard Form Factors

Figure 4 illustrates a perspective view of a non-limiting example of a droplet operations drive configuration 400, which is a non-limiting example of a desktop computer-specific configuration. More specifically, Figure 4 shows a standard desktop computer 410 that includes standard 5.25 inch-drive bays 414, such as drive bays 414a, 414b, and 414c. In one example, a standard 5.25 inch-CD-ROM drive 418 is installed in drive bay 414a, a droplet operations drive 422 is installed in drive bay 414b, and a droplet operations drive 426 is installed in drive bay 414c. Droplet operations drives 422 and 426 are substantially the same as droplet operations drive 100 of Figure 1, except that the bodies thereof have the same 5.25 inch-form factor as the standard 5.25 inch-drive bays 414. Droplet operations drives 422 and 426 include standard desktop computer power and signal connectors. In this way, a droplet operations drive may be installed in any standard desktop computer. More specifically, a user is provided one or more droplet operations drives and associated analysis software, which may be installed in the user's existing desktop computer.

Droplet operations drive configuration 400 is not limited to the configuration shown in Figure 1. Figure 1 is exemplary only. Droplet operations drive configuration 400 may include any number and combination of droplet operations drives and standard desktop computer drives (e.g., CD-ROM drive, floppy drive, etc).

Figure 5 illustrates a perspective view of a non-limiting example of a droplet operations drive configuration 500, which is a non-limiting example of a laptop computer-specific configuration. More specifically, Figure 5 shows a standard laptop computer 510 that includes standard laptop computer drive bay 514, such as a standard laptop computer CD-ROM or floppy drive bay. In one example, a droplet operations drive 520 is installed in drive bay 514. Droplet operations drive 520 is substantially the same as droplet operations drive 100 of Figure 1, except that the body thereof has the same form factor as standard laptop computer drive bay 514. Droplet operations drive 520 includes standard laptop computer power and signal connectors. In this way, droplet operations drive 520 may be installed in any standard laptop computer. More specifically, a user is provided a droplet operations drive 520 and associated analysis software, which may be installed in his/her existing laptop computer.

Droplet operations drive 520 may include, for example, a standard slot for inserting a droplet actuator cartridge 110, such as described in droplet operations drive 100 of Figure 1. Alternatively, and referring again to Figure 5, droplet operations drive 520 may include a tray 524, which is similar to a standard CD-ROM tray, having a receptacle integrated therein for accepting a droplet actuator 528.

Alternatively, a droplet operations drive is designed to plug into the personal computer memory card international association (PCMCIA) card slot (not shown) of a standard laptop computer or an SD card or flash memory reader slot such as a USB slot.

Alternatively and referring again to Figures 4 and 5, the droplet operations drives may be provided as external drives (not shown) that may be connected to any standard computer (e.g., any standard desktop or laptop computer) in a wired fashion (e.g., USB connection, FireWire connection, or a parallel port or serial port connection; in this case the drive will include a separate power supply) or in a wireless fashion (e.g., Bluetooth™ or IEEE 802.11 technology).

Alternatively and referring again to Figures 4 and 5, a droplet operations drive may be integrated in a handheld computing device, into which a droplet actuator cartridge may be inserted. A droplet operations drive may also be interfaced with the secure-digital (SD) card slot on a handheld smartphone or a personal digital assistant or any mobile phone which can use the data communication capabilities of the mobile phone to communicate with a physician or a laboratory information system (LIS) or hospital information system (HIS).

Additionally, droplet operations drives, such as droplet operations drives 422 and 426 of Figure 4 and droplet operations drive 520 of Figure 5, which have standard drive bay form factors, may be easily installed in existing networked computers and used with existing standard communications protocols, in order to facilitate any number of applications. In one example, droplet operations drives may be installed in an existing network for enabling a bio-threat monitoring application. Alternatively, a portable bio-threat detection system may be formed by installing a droplet operations drives in any laptop computer.

5.4 Droplet Actuator and Sensors

For examples of droplet actuator architectures that are suitable for use with the present invention, see U.S. Patent 6,911,132, entitled, "Apparatus for Manipulating Droplets by Electrowetting-Based Techniques," issued on June 28, 2005 to Pamula et al.; U.S. Patent Application No. 11/343,284, entitled, "Apparatuses and Methods for Manipulating Droplets on a Printed Circuit Board," filed on January 30, 2006; U.S. Patents 6,773,566, entitled, "Electrostatic Actuators for Microfluidics and Methods for Using Same," issued on August 10, 2004 and 6,565,727, entitled, "Actuators for Microfluidics Without Moving Parts," issued on January 24, 2000, both to Shenderov et al.; Pollack et al., International Patent Application No. PCT/US 06/47486, entitled, "Droplet-Based Biochemistry," filed on December 11, 2006, the disclosures of which are incorporated herein by reference. International Patent Application No. PCT/US 07/09379, entitled "Droplet Manipulation Systems," describes user interfaces, cartridge and droplet actuator electronics that are suitable for use in the present invention, the entire disclosure of which is incorporated herein by reference.

5.5 Method of Using a Standalone Droplet Operations Drive

A method of using a standalone, assay-specific, droplet operations drive includes, but is not limited to, one or more of the following steps. (1) electrically coupling a certain assay-specific droplet operations drive to a user interface device, such as a desktop or laptop computer; (2) selecting a certain assay-specific (includes multiple specific assays or assay types) droplet actuator cartridge; (3) inserting the certain assay-specific droplet actuator cartridge into the slot of the assay-specific droplet operations drive; (4) executing the assay-specific analysis software; (5) receiving a certain set of assay-specific assay results; (6) removing the certain assay-specific droplet actuator cartridge from the assay-specific droplet operations drive; (7) inserting a next type of assay-specific droplet actuator cartridge into slot of the assay-specific droplet operations drive; (8) executing the assay-specific analysis software; (9) receiving a next set of assay-specific assay results; and (10) repeating steps 6 through 9 for any number of assay-specific droplet actuator cartridges.

This specification is divided into sections for the convenience of the reader only. Headings should not be construed as limiting of the scope of the invention.

It will be understood that various details of the present invention may be changed without departing from the scope of the present invention. Various aspects of each embodiment described here may be interchanged with various aspects of other embodiments. Furthermore, the foregoing description is for the purpose of illustration only, and not for the purpose of limitation.

The Claims

We claim:

1. A droplet actuator drive comprising:
 - (a) a detection apparatus for sensing a property of a droplet on a droplet actuator;
 - (b) circuitry for controlling the detection apparatus electronically coupled to the detection apparatus;
 - (c) a droplet actuator cartridge connector arranged so that when a droplet actuator cartridge electronically is coupled thereto:
 - (i) the droplet actuator cartridge is aligned with the detection apparatus; and
 - (ii) the detection apparatus can sense the property of the droplet on a droplet actuator;
 - (d) circuitry for controlling a droplet actuator coupled to the droplet actuator connector; and
 - (e) means for coupling the droplet actuator circuitry to a processor.
2. The droplet actuator drive of claim 1 wherein the means for coupling the circuitry to a processor comprises:
 - (a) a set of connections for electrically coupling the circuitry to a computer; and/or
 - (b) means for wirelessly coupling the circuitry to a computer.
3. The droplet actuator drive of claim 1 wherein the means for coupling the circuitry to a processor comprises a droplet actuator drive configured for insertion in and electronic coupling to a computer via a drive bay of a desktop or laptop computer.

4. The droplet actuator drive of claim 1 configured as a desktop drive.
5. The droplet actuator drive of claim 1 wherein:
 - (a) the droplet actuator cartridge connector comprises a slide-out tray; and
 - (b) electronically coupling the droplet actuator cartridge connector to the processor comprises:
 - (i) opening the slide-out tray;
 - (ii) inserting the droplet actuator cartridge into the slide-out tray; and
 - (iii) closing the slide-out tray.
6. The droplet actuator drive of claim 1 wherein the means for coupling the droplet actuator circuitry to a processor comprises providing the droplet actuator drive in a configuration suitable for insertion into a memory stick slot.
7. The droplet actuator drive of claim 1 wherein the means for coupling the droplet actuator circuitry to a processor comprises providing the droplet actuator drive in a configuration suitable for insertion into a USB port.
8. The droplet actuator drive of claim 1 wherein the means for coupling the droplet actuator circuitry to a processor comprises a male USB connector integrated with the droplet actuator drive.
9. The droplet actuator drive of claim 1 comprising two or more of the droplet actuator cartridge connectors.
10. The droplet actuator drive of claim 2 wherein the two or more of the droplet actuator cartridge connectors comprise two or more connectors each configured for a different droplet actuator cartridge specific for a different droplet actuator test type.

11. The droplet actuator drive of claim 1 further comprising an output mechanism for providing output indicative of sensing by the detection apparatus of a property of a droplet on the droplet actuator.
12. The droplet actuator drive of claim 1 further comprising means for coupling the detector circuitry to a processor.
13. The droplet actuator drive of claim 1 wherein the droplet actuator cartridge connector comprises a slot configured for insertion of a droplet actuator cartridge.
14. A system comprising the droplet actuator drive of claim 1 and further comprising a processor coupled to the means for coupling the detector circuitry to a processor.
15. The droplet actuator drive of claim 1 wherein the detection apparatus comprises a sensor for sensing photons emitted from and/or transmitted through a droplet on the droplet actuator.
16. The droplet actuator drive of claim 1 further comprising a droplet actuator cartridge electronically coupled to the droplet actuator cartridge connector.
17. The droplet actuator drive of claim 2 wherein the droplet actuator cartridge comprises an optically transparent region which aligns with the detection apparatus, permitting sensing of a property of a droplet on a droplet actuator.
18. The droplet actuator drive of claim 2 further comprising:
 - (a) reagents for a predetermined assay type pre-loaded on the droplet actuator cartridge; and
 - (b) a sample loaded on the droplet actuator cartridge prior to insertion into the slot.
19. The droplet actuator drive of claim 18 wherein the reagents comprise nucleic acid amplification reagents.

20. The droplet actuator drive of claim 18 wherein the reagents comprise immunoassay reagents.
21. The droplet actuator drive of claim 18 wherein the reagents comprise biochemistry reagents.
22. A system comprising a processor coupled to the circuitry of the droplet actuator drive of claim 1 by the means for coupling the droplet actuator circuitry to a processor and programmed to control the droplet actuator and/or detection apparatus.
23. The system of claim 22 wherein the processor is comprised in a computer selected from the group consisting of desktop computers, laptop computers, and handheld computers.
24. The system of claim 23 further comprising a droplet actuator cartridge electronically coupled to the droplet actuator cartridge connector.
25. A kit comprising packaging comprising:
 - (a) a droplet actuator drive comprising:
 - (i) a detection apparatus for sensing a property of a droplet on a droplet actuator;
 - (ii) circuitry for controlling the detection apparatus electronically coupled to the detection apparatus;
 - (iii) a droplet actuator cartridge connector arranged so that when a droplet actuator cartridge is electronically coupled thereto:
 - (1) the droplet actuator cartridge is aligned with the detection apparatus; and
 - (2) the detection apparatus can sense the property of the droplet on a droplet actuator;

- (iv) circuitry for controlling a droplet actuator coupled to the droplet actuator connector;
 - (v) means for coupling the droplet actuator circuitry to a processor; and
 - (b) a droplet actuator cartridge comprising a droplet actuator and means for coupling the droplet actuator cartridge to the droplet actuator drive.
26. The kit of claim 25 further comprising beads for conducting an assay using the droplet actuator cartridge.
27. The kit of claim 26 wherein the beads are loaded on the droplet actuator cartridge.
28. The kit of claim 25 further comprising instructions for using the kit.
29. The kit of claim 28 wherein the instructions are electronically stored on an electronic storage medium associated with the cartridge such that when coupled to a droplet actuator drive, the instructions are displayed on an output device associated with the droplet actuator drive and or a system comprising the droplet actuator drive.
30. A kit comprising:
- (a) a droplet actuator cartridge comprising:
 - (i) a droplet actuator; and
 - (ii) means for coupling the droplet actuator cartridge to a droplet actuator drive; and
 - (b) instructions for using the droplet actuator cartridge.
31. The kit of claim 30 further comprising beads for conducting an assay using the droplet actuator cartridge.
32. The kit of claim 31 wherein the beads are loaded on the droplet actuator cartridge.

33. The kit of claim 32 further comprising instructions for using the kit.
34. The kit of claim 33 wherein the instructions are electronically stored on an electronic storage medium associated with the cartridge such that when coupled to a droplet actuator drive, the instructions are displayed on an output device associated with the droplet actuator drive and or a system comprising the droplet actuator drive.
35. A method of conducting an assay, the method comprising:
- (a) providing a droplet actuator drive comprising:
 - (i) a detection apparatus for sensing a property of a droplet on a droplet actuator;
 - (ii) circuitry for controlling the detection apparatus electronically coupled to the detection apparatus;
 - (iii) a droplet actuator cartridge connector arranged so that when a droplet actuator cartridge electronically coupled thereto:
 - (1) the droplet actuator cartridge is aligned with the detection apparatus; and
 - (2) the detection apparatus can sense the property of the droplet on a droplet actuator;
 - (iv) circuitry for controlling a droplet actuator coupled to the droplet actuator connector;
 - (v) means for coupling the droplet actuator circuitry to a processor; and
 - (b) electronically coupling the droplet actuator drive to a computer processor;
 - (c) coupling a droplet actuator cartridge to a droplet actuator cartridge connector, the cartridge comprising reagent sample for an assay protocol;

- (d) executing software using the computer processor to effect steps comprising:
 - (i) executing steps in the assay protocol;
 - (ii) sensing a property of an assay droplet; and
 - (iii) displaying an output indicative of the property of the assay droplet.
- 36. The method of claim 35 wherein step 35(d)(i) comprises conducting one or more droplet operations using droplets comprising one or more beads.
- 37. The method of claim 35 wherein step 35(d)(i) comprises conducting one or more droplet operations using droplets comprising one or more biological cells.
- 38. The method of claim 35 wherein step 35(d)(i) comprises conducting one or more dispensing or splitting droplet operations using droplets comprising beads.
- 39. The method of claim 35 wherein step 35(d)(i) comprises conducting one or more dispensing or splitting droplet operations using droplets comprising biological cells.
- 40. The method of claim 35 wherein step 35(d)(i) comprises conducting one or more dispensing or splitting droplet operations using droplets comprising viable biological cells.
- 41. The method of claim 35 wherein step 35(d)(i) comprises conducting one or more washing operations using magnetically responsive beads.
- 42. The method of claim 35 wherein step 35(d)(i) comprises conducting one or more washing operations using substantially non-magnetically responsive beads.
- 43. The method of claim 35 wherein the property of the assay droplet sensed in step 35(d)(ii) is indicative of a property of one or more beads in the assay droplet.
- 44. The method of claim 35 wherein the property of the assay droplet sensed in step 35(d)(ii) is indicative of a property of one or more biological cells in the assay droplet.

45. The method of claim 35 wherein the output displayed in step 35(d)(iii) is indicative of a property of one or more beads in the assay droplet.
46. The method of claim 35 wherein the output displayed in step 35(d)(iii) is indicative of a property of one or more cells in the assay droplet.

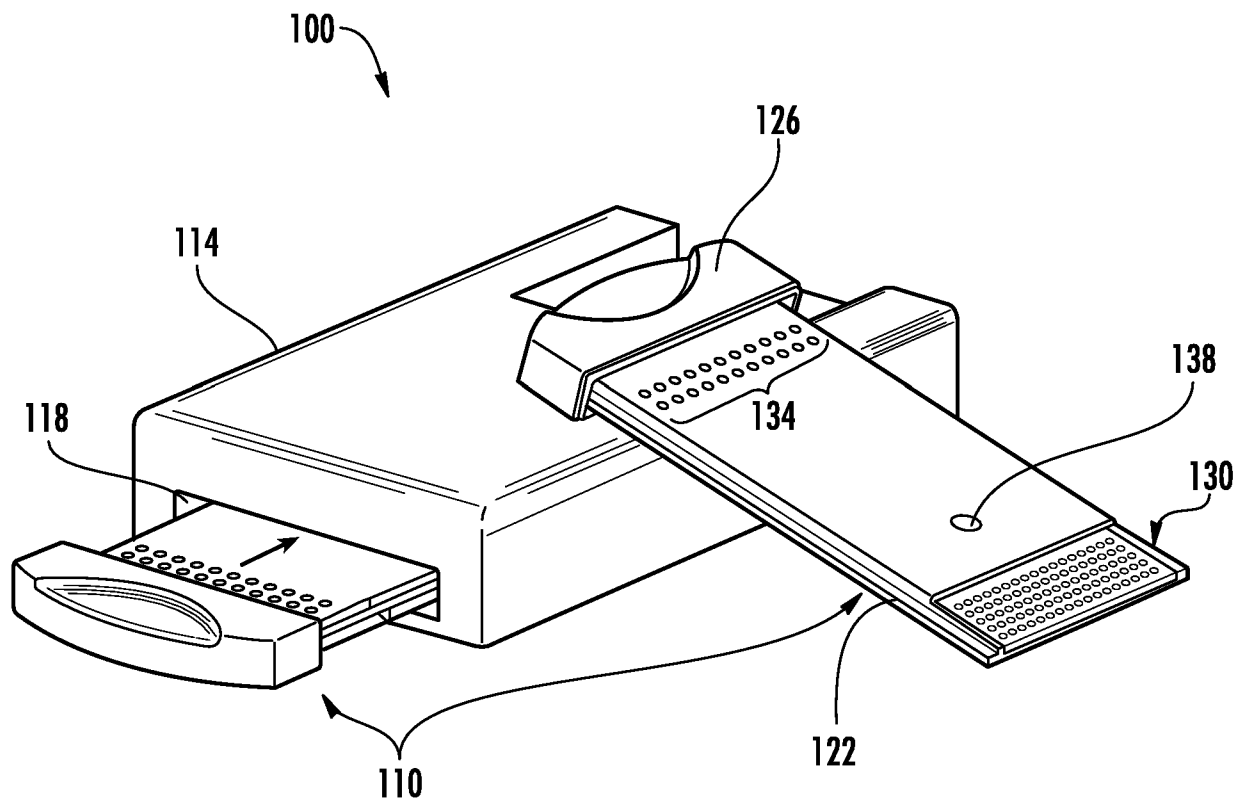

FIG. 1

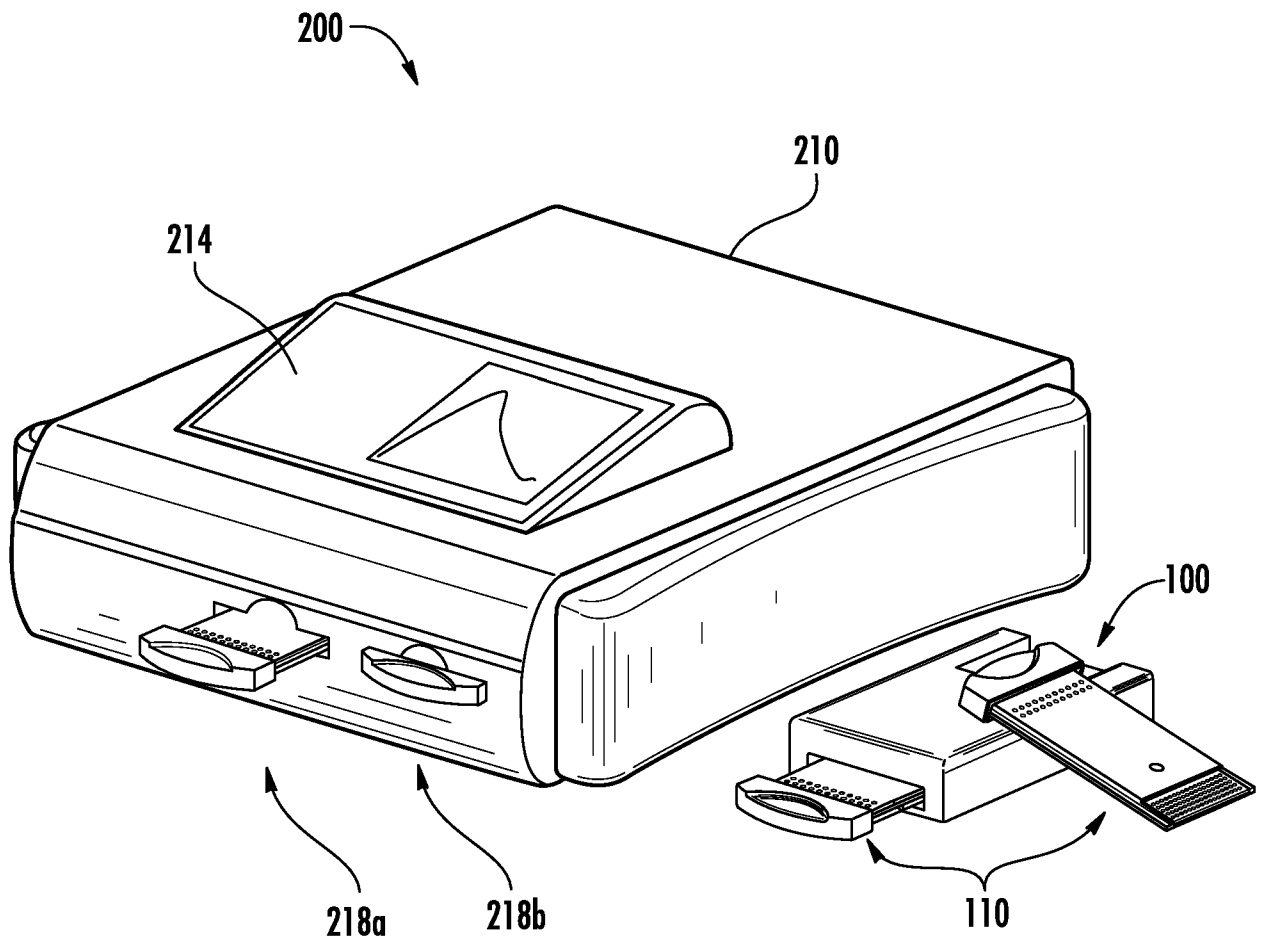

FIG. 2

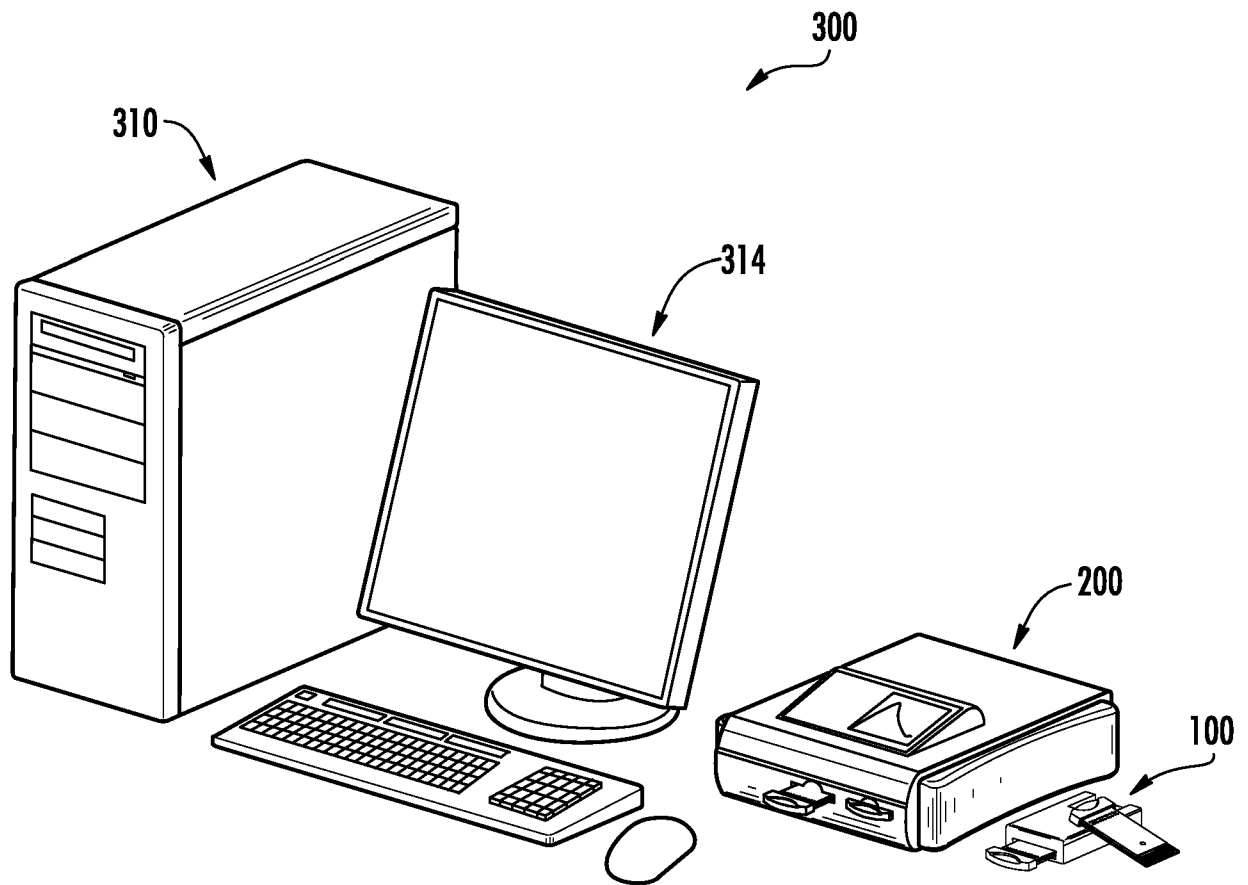

FIG. 3

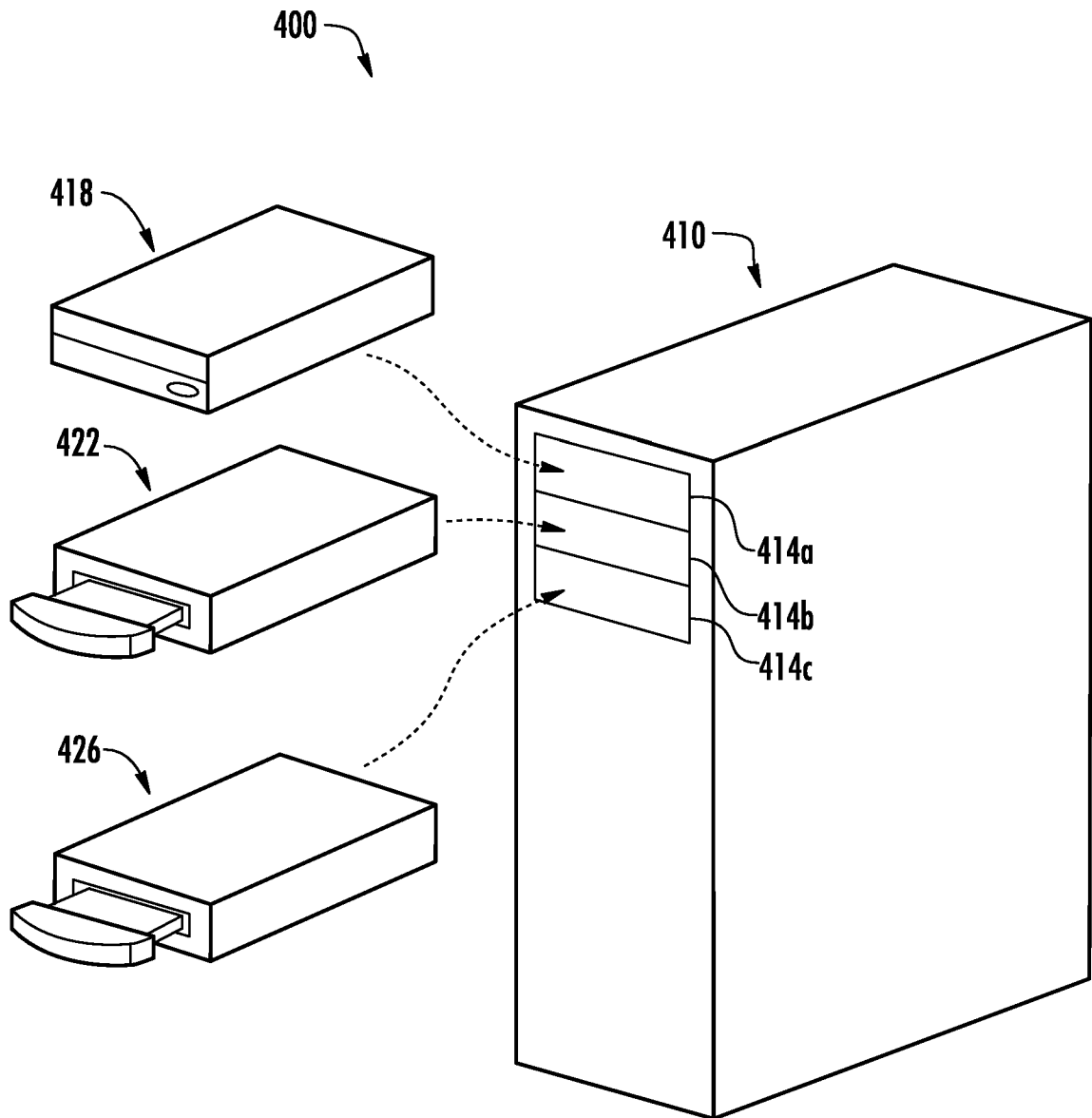

FIG. 4

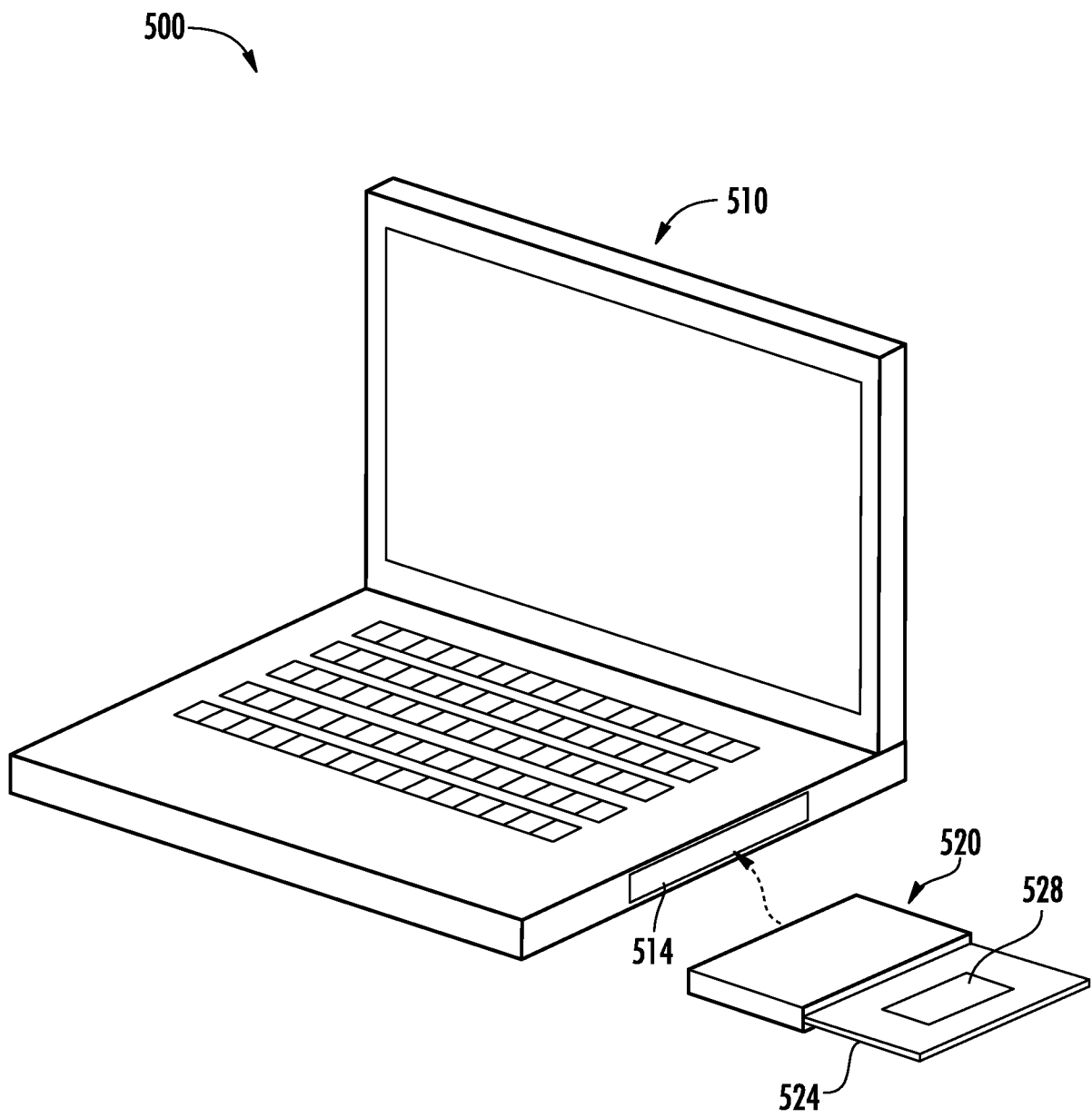

FIG. 5